

Cod. Code 7003669	Peso totale Total weight 75 Kg	Materiale Construction ACCIAIO INOX AISI 316L STAINLESS STEEL AISI 316L	Girante Impeller DRENAGGIO DRAINAGE
-----------------------------	--	---	---

Idraulica - Hydraulic	
MANDATA DISCHARGE	40 mm
ASPIRAZIONE SUCTION	mm
PASSAGGIO LIBERO FREE PASSAGE	7 mm
DIAMETRO GIRANTE IMPELLER DIAMETER	192 mm

Motore- Motor		M210T-6-400/50NY-IE3EX		
ALIMENTAZIONE POWER SUPPLY	3ph 400/690V-50Hz			
CLASSE DI ISOLAMENTO INSULATION CLASS	H Trop			
VELOCITÀ NOMINALE NOMINAL SPEED	2842 rpm			
POTENZA NOMINALE MOTORE RATED MOTOR POWER	6,0 kW			
CORRENTE DI SPUNTO STARTING CURRENT	64,3 A			
CORRENTE NOMINALE RATED CURRENT	10,9 A			
MOMENTO DI INERZIA TOTALE TOTAL MOMENT OF INERTIA	0,0156 kgm2			
	CARICO-LOADING			
	4/4	3/4	1/2	
FATTORE DI POTENZA POWER FACTOR	0,88	0,84	0,73	
RENDIMENTO MOTORE MOTOR EFFICIENCY	90 %	89 %	88 %	

Impiego - Application	
TEMP. MAX DEL LIQUID PUMPED LIQUID MAX TEMP.	< 45 °C
PROTEZIONE MECCANICA MECHANICAL PROT. DEGREE	IP 68
CAVO CABLE	12G1,5 H07RNF
CODICE DISEGNO DRAWING CODE	710_40_10_3
CURVA CURVE	D710-205

Rend. max - Best efficiency	
RENDIMENTO TOTALE TOTAL EFFICIENCY	40,7 %
RENDIMENTO IDRAULICO HYDRAULIC EFFICIENCY	45,1 %
POT. ASS. DALLA RETE ABS. POWER FROM MAINS	5,5 kW
PREVALENZA HEAD	26,6 m
PORTATA CAPACITY	31,0 m³/h

Protezioni - Protections	
PROTEZIONE TERMICA THERMAL PROTECTION	<input checked="" type="checkbox"/> YES
CONTROLLO INFILTRAZIONE HUMIDITY PROBE	<input type="checkbox"/> NO
II 2G Ex c k db IIB T4 Gb	<input checked="" type="checkbox"/> YES
MANTELLINO DI RAFFREDDAMENTO COOLING JACKET	<input type="checkbox"/> NO

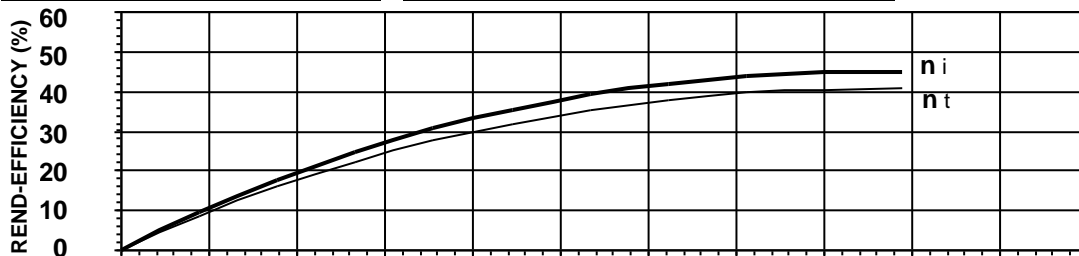

η_i = Rendimento idraulico
Hydraulic efficiency

η_t = Rendimento totale
Total efficiency

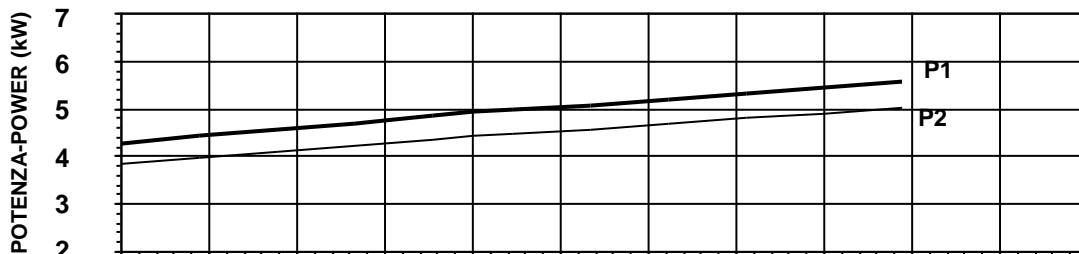

P1 = Potenza ass. dalla rete
Abs. power from mains

P2 = Potenza idraulica
Hydraulic power

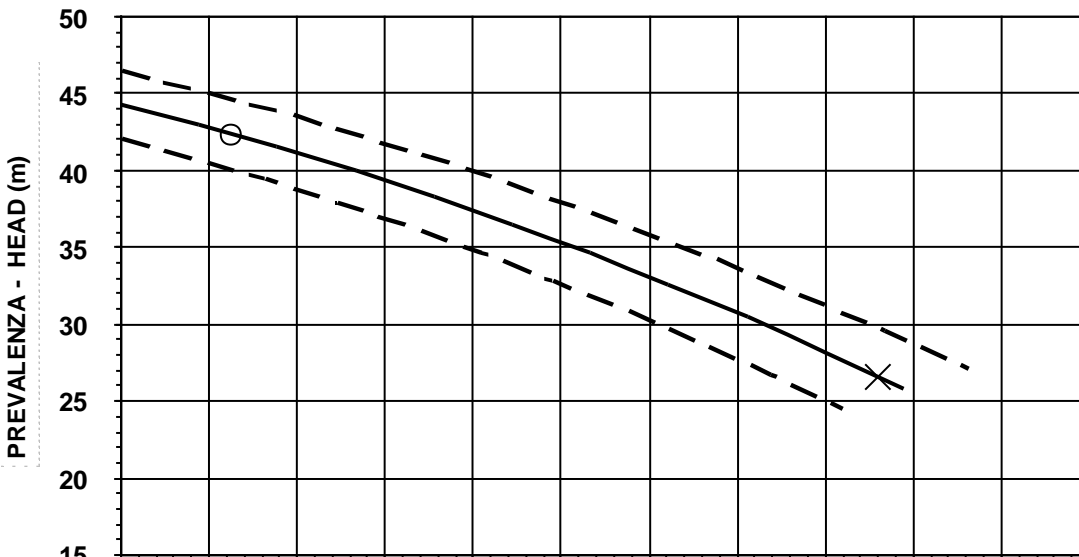

O = Portata minima
Minimum capacity

X = Punto max rendimento
Best efficiency point



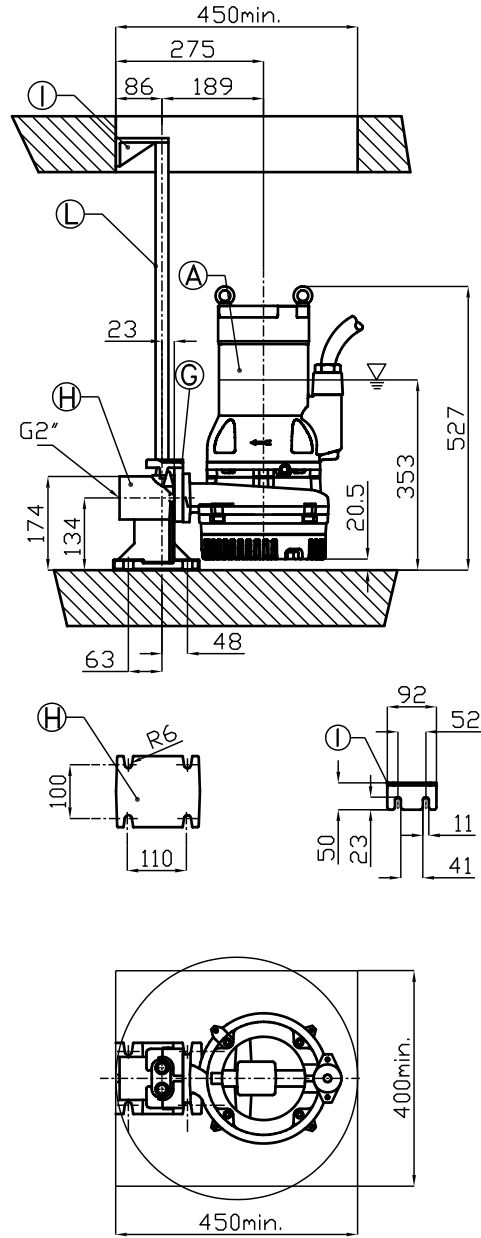
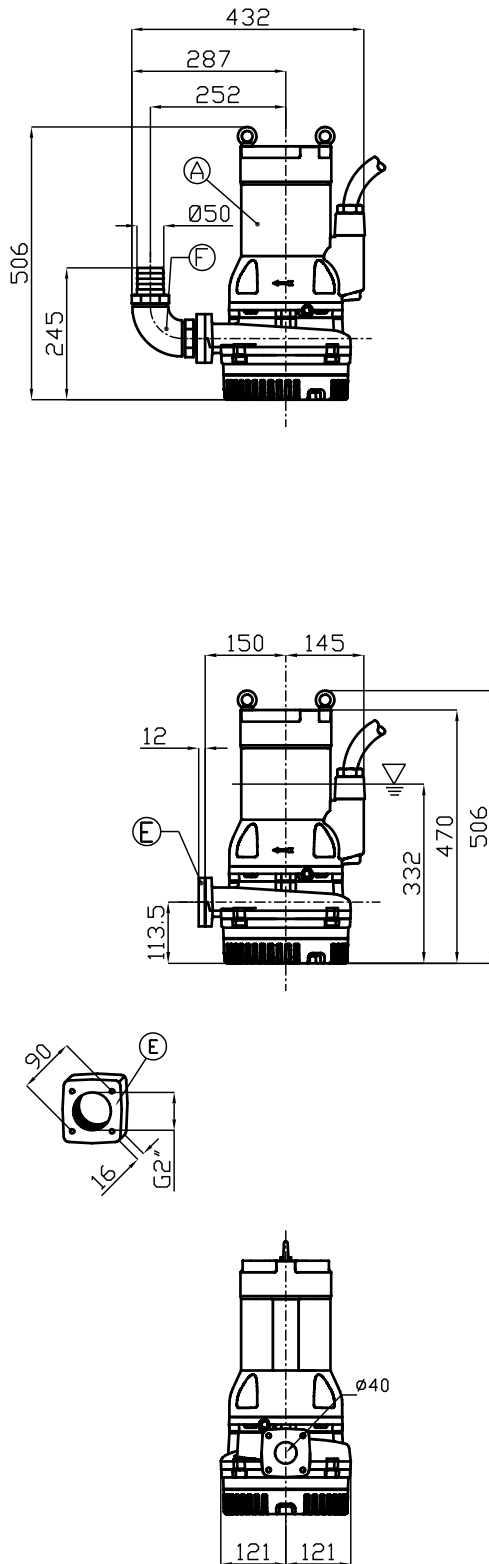

R

Pos.	Codice	Descrizione	Materiale	Peso Kg
Pos.	Code	Description	Material	Weight Kg
A	-	Elettropompa Sommersibile Submersible Pump	-	-
B	54.09310	Guarnizione DN50 Rubber joint DN50	Neoprene Neoprene	0,01
Type: R XPADN502T/L				
G	XCADN502T/L	Controflangia accoppiamento 2 guide DN50 Double guide rail coupling flange DN50	AISI316L Acciaio S.Steel AISI316L	3
H	XBPACDN502T/L	Piede d'accoppiamento 2 guide DN50 Double guide coupling feet DN50	AISI316L Acciaio S.Steel AISI316L	7
I	SOP2TDN50/3	Sopporto tubi superiore 2 guide 3/4 Double guide rail upper support 3/4	AISI316L Acciaio S.Steel AISI316L	1,9
L	TG3/4X6L	Tubo guida 3/4 Guide rail 3/4	AISI316L Acciaio S.Steel AISI316L	-
Type: S				
E	XF2	Flangetta filettata 2" Threaded flange 2"	AISI316 Acciaio S.Steel AISI316	1
F	XC50	Curva di mandata 90° Ø50 Delivery elbow 90° Ø50	AISI316 Acciaio S.Steel AISI316	3

▽ LIVELLO MINIMO DI SOMMERSIBILITÀ STANDARD.
▽ PER VERSIONE ATEX, COMPLETAMENTE SOMMERSA.

▽ MINIMUM SUBMERSIBLE LEVEL STANDARD.
▽ FOR ATEX TYPE, COMPLETELY SUBMERGED.

S