

Cod. Code 7003657	Peso totale Total weight 61 Kg	Materiale Construction BRONZO MARINO MARINE BRONZE	Girante Impeller DRENAGGIO DRAINAGE
--------------------------	---------------------------------------	-----------------------------------------------------------	--------------------------------------------

Idraulica - Hydraulic	
MANDATA DISCHARGE	40 mm
ASPIRAZIONE SUCTION	mm
PASSAGGIO LIBERO FREE PASSAGE	7 mm
DIAMETRO GIRANTE IMPELLER DIAMETER	155 mm

Motore- Motor M209T-3,6-400/50NN-IE3	
ALIMENTAZIONE POWER SUPPLY	3ph 400V-50Hz
CLASSE DI ISOLAMENTO INSULATION CLASS	H
VELOCITÀ NOMINALE NOMINAL SPEED	2822 rpm
POTENZA NOMINALE MOTORE RATED MOTOR POWER	3,6 kW
CORRENTE DI SPUNTO STARTING CURRENT	38,9 A
CORRENTE NOMINALE RATED CURRENT	6,6 A
MOMENTO DI INERZIA TOTALE TOTAL MOMENT OF INERTIA	0,0055 kgm²
	CARICO-LOADING
	4/4 3/4 1/2
FATTORE DI POTENZA POWER FACTOR	0,88 0,84 0,71
RENDIMENTO MOTORE MOTOR EFFICIENCY	89 % 87 % 86 %

Impiego - Application	
TEMP. MAX DEL LIQUID PUMPED LIQUID MAX TEMP.	< 40 °C
PROTEZIONE MECCANICA MECHANICAL PROT. DEGREE	IP 68
CAVO CABLE	4G2,5 H07RNF
CODICE DISEGNO DRAWING CODE	710_40_09_5
CURVA CURVE	D710-225

Rend. max - Best efficiency	
RENDIMENTO TOTALE TOTAL EFFICIENCY	38,8 %
RENDIMENTO IDRAULICO HYDRAULIC EFFICIENCY	43,5 %
POT. ASS. DALLA RETE ABS. POWER FROM MAINS	2,9 kW
PREVENZA HEAD	18,6 m
PORTATA CAPACITY	22,6 m³/h

Protezioni - Protections	
PROTEZIONE TERMICA THERMAL PROTECTION	<input type="checkbox"/> NO
CONTROLLO INFILTRAZIONE HUMIDITY PROBE	<input type="checkbox"/> NO
II 2G Ex c k db IIB T4 Gb	<input type="checkbox"/> NO
MANTELLINO DI RAFFREDDAMENTO COOLING JACKET	<input type="checkbox"/> NO

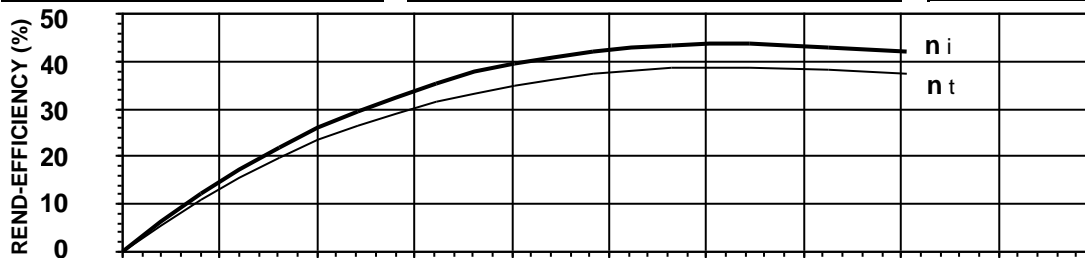

η_i = Rendimento idraulico
Hydraulic efficiency

η_t = Rendimento totale
Total efficiency

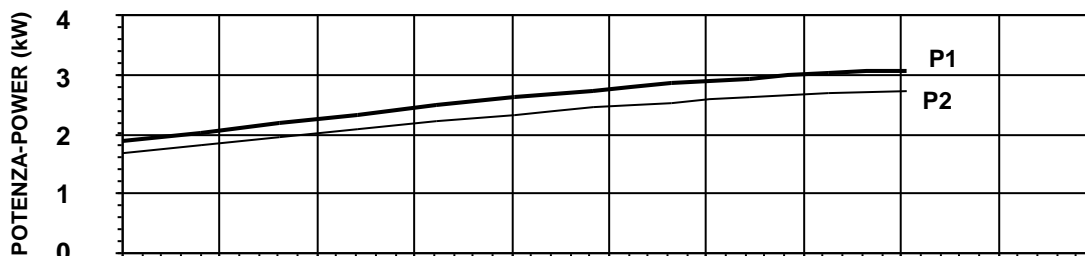

P1 = Potenza ass. dalla rete
Abs. power from mains

P2 = Potenza idraulica
Hydraulic power

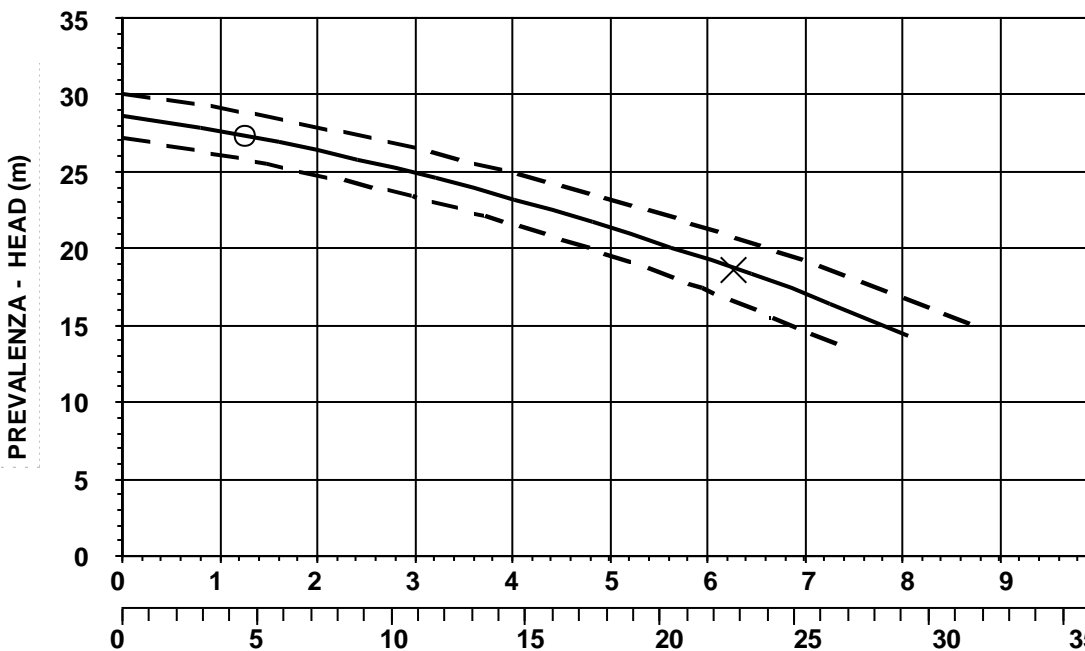

O = Portata minima
Minimum capacity

X = Punto max rendimento
Best efficiency point



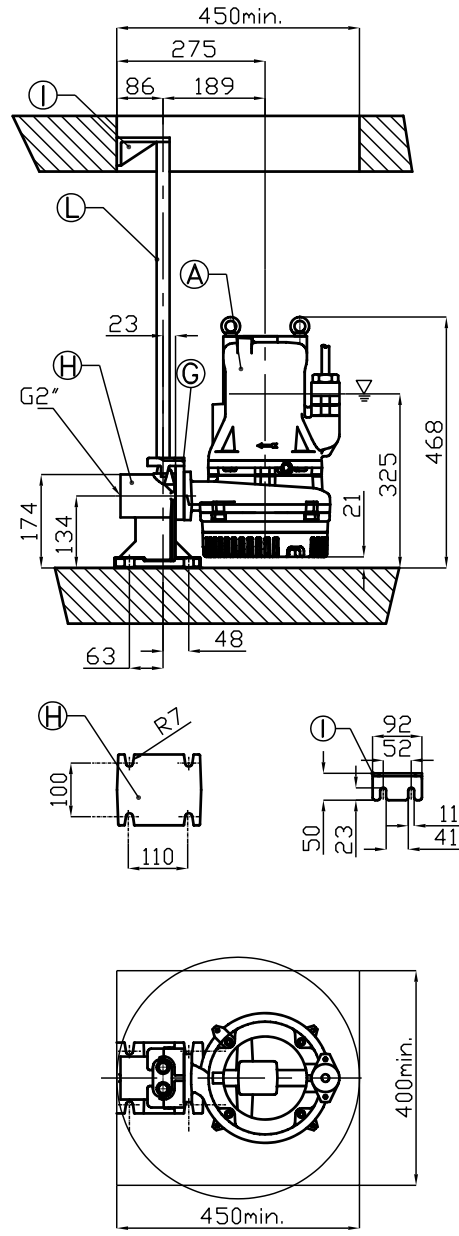
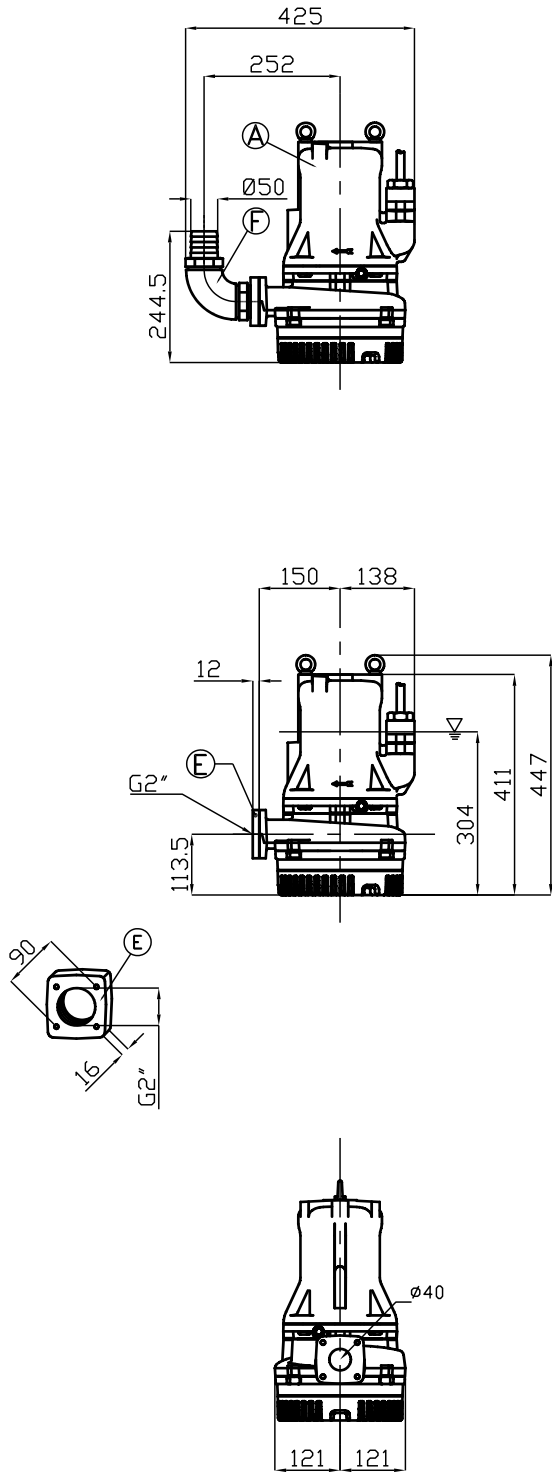

Pos.	Codice	Descrizione	Materiale	Peso Kg
Pos.	Code	Description	Material	Weight Kg
A	-	Elettropompa Sommersibile Submersible Pump	-	-
B	54.09310	Guarnizione DN50 Rubber joint DN50	Neoprene Neoprene	0,01
Type: R XPADN502T/L				
G	XCADN502T/L	Controflangia accoppiamento 2 guide DN50 Double guide rail coupling flange DN50	AISI316L Acciaio S.Steel AISI316L	3
H	XBPACDN502T/L	Piede d'accoppiamento 2 guide DN50 Double guide coupling feet DN50	AISI316L Acciaio S.Steel AISI316L	7
I	SOP2TDN50/3	Sopperto tubi superiore 2 guide 3/4 Double guide rail upper support 3/4	AISI316L Acciaio S.Steel AISI316L	1,9
L	TG3/4X6L	Tubo guida 3/4 Guide rail 3/4	AISI316L Acciaio S.Steel AISI316L	-
Type: S				
E	XF2	Flangetta filettata 2" Threaded flange 2"	AISI316 Acciaio S.Steel AISI316	1
F	XC50	Curva di mandata 90° Ø50 Delivery elbow 90° Ø50	AISI316 Acciaio S.Steel AISI316	3

∇ LIVELLO MINIMO DI SOMMERGIBILITÀ STANDARD.
PER VERSIONE ATEX, COMPLETAMENTE SOMMERSA.

∇ MINIMUM SUBMERSIBLE LEVEL STANDARD.
FOR ATEX TYPE, COMPLETELY SUBMERGED.

S