

TROJAN GRINDER

A compact complete unit supplied with pumps, valves and control panel, which is easily installed and maintained. For use in waste water or sewage applications where removal is not possible under gravity, such as a single dwelling and multiple developments.



Grinding System

Features

- Polyethylene chamber
- 55L or 150L capacity
- Complete unit fitted with high efficiency single / dual vortex pumps
- 1.7kW or 3.2kW options
- DN80 or DN32 inlet
- Single DN32 outlet
- Dual DN50 outlet connection on Y-pipe
- Pneumatic level control with LCD display, fault and alarm options available

Performance Data

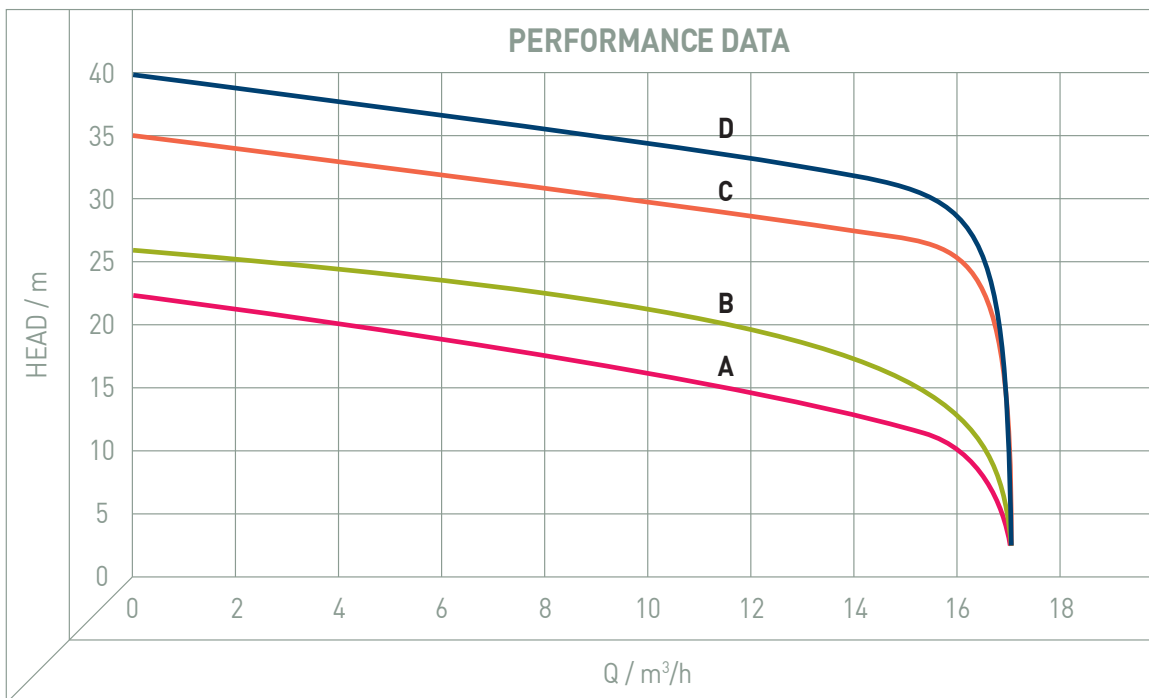

Technical Specification

PUMP TYPE	CURVE	OUTPUT		MAXIMUM		RPM	CAPACITY (l)	FREE PASSAGE mm	WEIGHT (kg)
		amp	kW	HEAD m	FLOW m ³ /h				
Trojan 55 VS 1.7/1 230 V	A \	10.5	1.7	22	17	2800	55	8.5	63
Trojan 55 VS 1.7/1 400 V	A \	3.7	1.7	22	17	2800	55	8.5	63
Trojan 55 VS 1.7/2 400 V	B \	3.7	1.7	25	17	2800	55	8.5	63
Trojan 55 VS 3.2/3 400 V	C \	6.5	3.2	35	17	2800	55	8.5	68
Trojan 55 VS 3.2/3 400 V	D \	6.5	3.2	39	17	2800	55	8.5	68
Trojan 150 VD 1.7/1 400 V	A \	3.7	1.7	22	17	2800	150	8.5	130
Trojan 150 VD 1.7/2 400 V	B \	3.7	1.7	25	17	2800	150	8.5	130
Trojan 150 VD 3.2/3 400 V	C \	6.5	3.2	35	17	2800	150	8.5	140
Trojan 150 VD 3.2/4 400 V	D \	6.5	3.2	39	17	2800	150	8.5	140
Manual hand pump	N/A	-	-	15	17	N/A	N/A	40	16



Manual hand pump available.

Dimensional Drawings

Trojan 55 Grinder Single

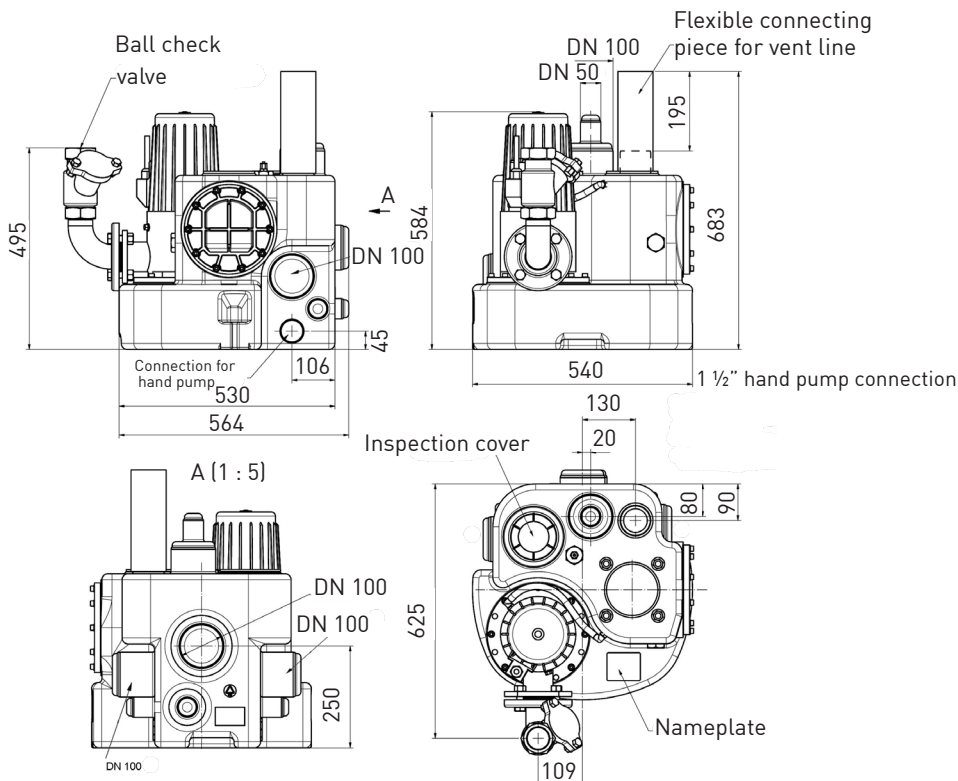

Trojan 150 Grinder Dual

