

available from **October 2022**

caprari



NEW PMA80 | PMA100

High pressure
multistage horizontal
pumps with

**AXIAL
SUCTION**

50 Hz

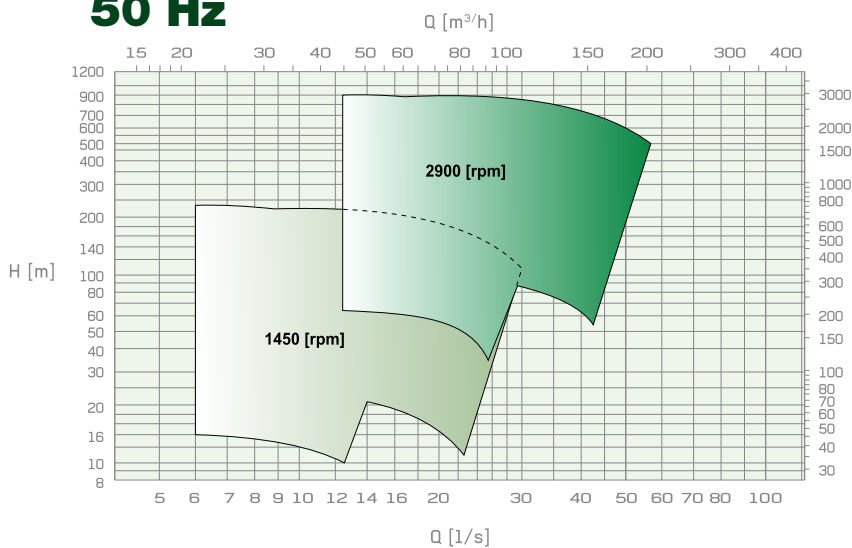

60 Hz

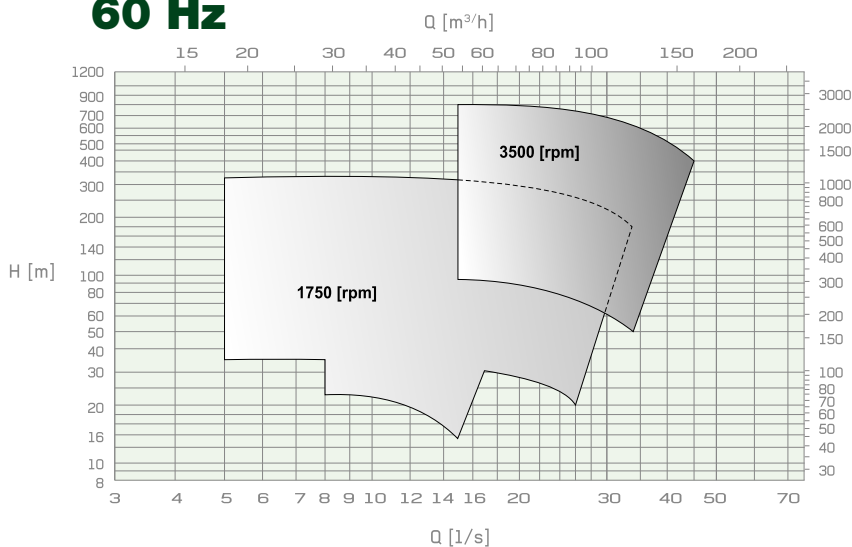

PMA80 PMA100

Sizes from-to	DNm 80 DNm 100
Flow Rate up to	55 l/s
Head up to	1000 m
Suction port	PN25 (PMA-PMAS) PN40 (PMAH)
Delivery port	PN40 (PMA) PN63 (PMAS) PN100 (PMAH)
Rotation speed (rpm)	1.450 - 3.500

IDEAL FOR

SNOWMAKING

WATER SUPPLY

INDUSTRIAL APPLICATIONS

FIRE-FIGHTING

IRRIGATION

WHY CHOOSE PMA?

1 PRESSURE UP TO 100 BAR

- Impellers with **axial thrust compensation** system
- **High thicknesses** of the casting components and **high performance materials**

2 HIGH ENERGY SAVING

- **High-efficiency hydraulics:** best in class efficiency
- Performance guaranteed over time: replaceable wear rings

3 REDUCED INSTALLATION COSTS

- **Simple installation:** suction casing axial to the pipeline
- **Easy pump-motor alignment:** innovative baseframes

4 LOW NPSH VALUES

- Reduces the risk of cavitation
- **Reliable** operation even in lifting installations

5 EASY MAINTENANCE

- **Reduced maintenance:** grease lubricated bearing on the delivery side
- **Quick replacement** of the sleeve and bushing from the suction side

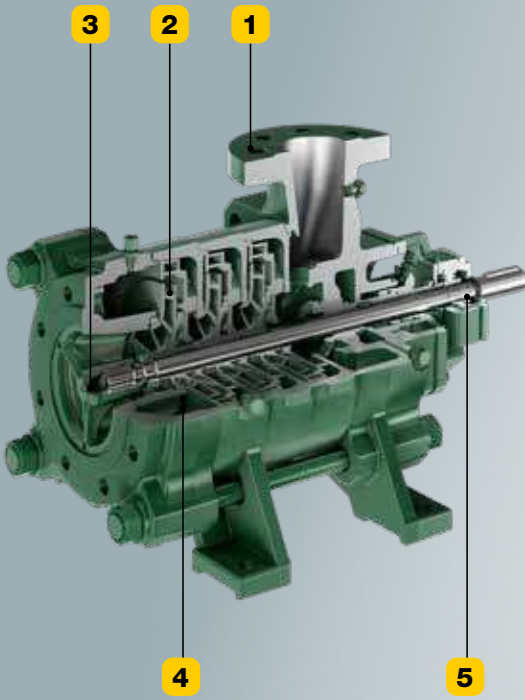

PMA65

PMA125

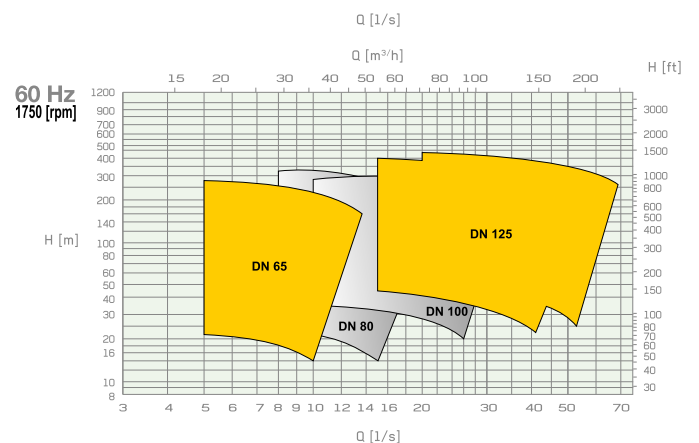
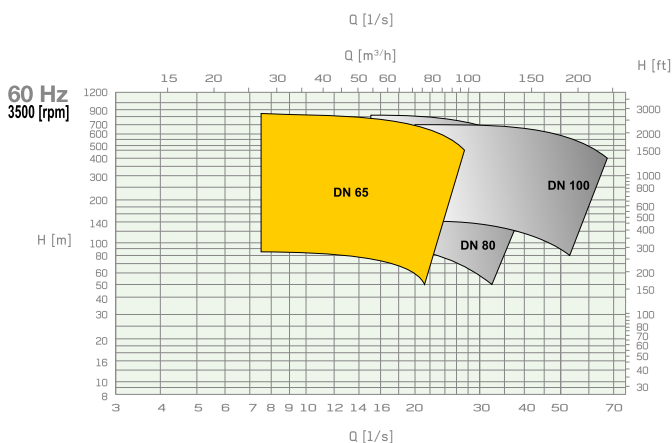
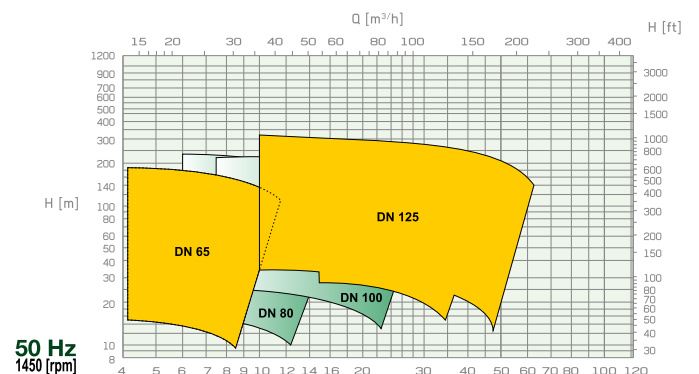
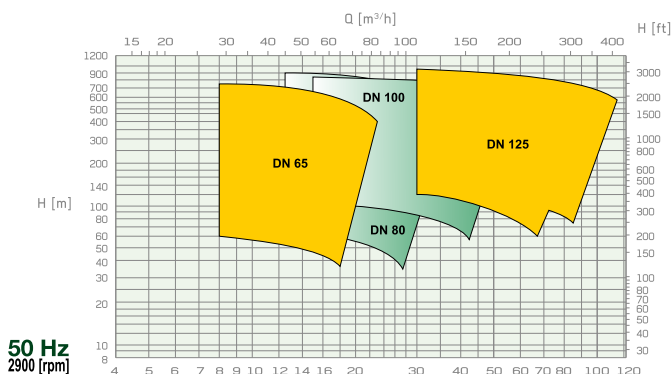

COMING SOON 2023

caprari

For information

Caprari S.p.A. | Via Emilia Ovest 900 | 41123 Modena
 Tel. +39 059 897611 | Fax +39 059 897897 | info@caprari.it
www.caprari.com

You can also follow us on

