

## TROJAN CHANNEL

A compact complete unit supplied with pumps and a control panel, which is easily installed and maintained.

For use in waste water or sewage applications where removal is not possible under gravity. Ideal for offices, schools, flats, hospitals, etc.

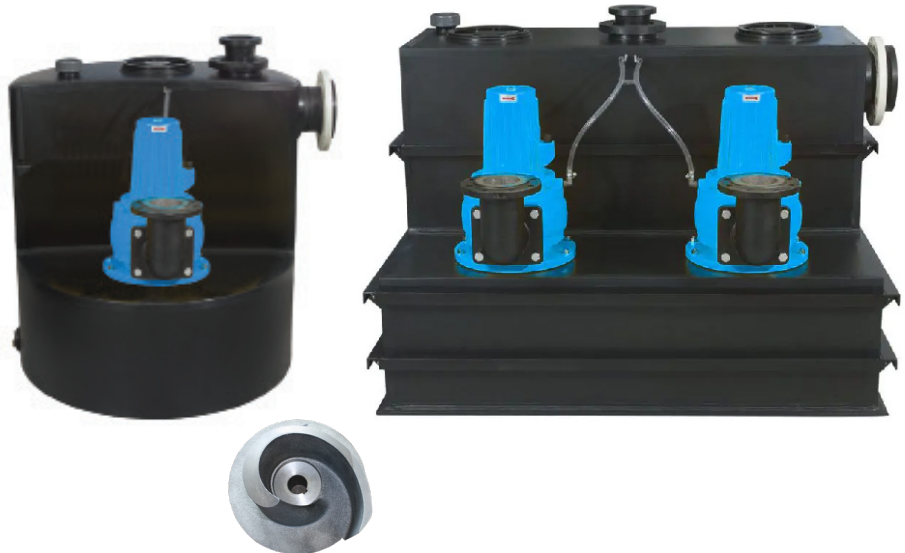

Channel Impeller

### Features

- Polyethylene chamber
- 480L or 1000L capacity
- Complete unit fitted with single / dual channel pumps
- 3.0kW, 4.0kW, 5.5kW or 7.5kW options
- DN150 inlet
- DN100 outlet
- Pneumatic level control with LCD display, fault and alarm options available

### Performance Data

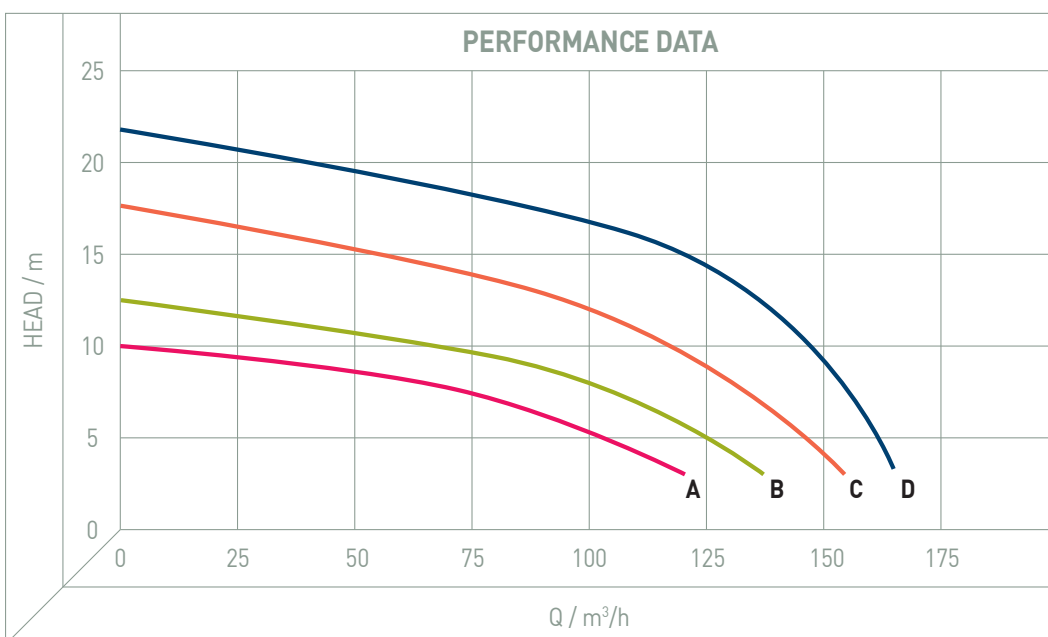

## Technical Specification

PUMP TYPE	CURVE	OUTPUT		MAXIMUM		RPM	CAPACITY (l)	FREE PASSAGE mm	WEIGHT kg
		amp	kW	Head m	Flow m <sup>3</sup> /h				
Trojan 480 CS 3.0 400V	A \	6.9	3.0	10	120	1400	480	80	210
Trojan 480 CS 4.0 400V	B \	11.2	4.0	13	140	1400	480	80	220
Trojan 480 CS 5.5 400V	C \	12.1	5.5	18	160	1400	480	100	225
Trojan 480 CS 7.5 400V	D \	16.9	7.5	22	165	1400	480	100	240
Trojan 1000 CS 3.0 400V	A \	6.9	3.0	10	120	1400	1000	80	370
Trojan 1000 CS 4.0 400V	B \	11.2	4.0	13	140	1400	1000	80	220
Trojan 1000 CS 5.5 400V	C \	12.1	5.5	18	160	1400	1000	100	225
Trojan 1000 CS 7.5 400V	D \	16.9	7.5	22	165	1400	1000	100	240
Manual hand pump	N/A	-	-	15	0.65L PER ACTION	N/A		40	16

Please note that the discharge pipework and valves are an optional extra for the 480 and 1000 models.



Manual hand pump available.

## Dimensional Drawings

Trojan 480 Channel Single

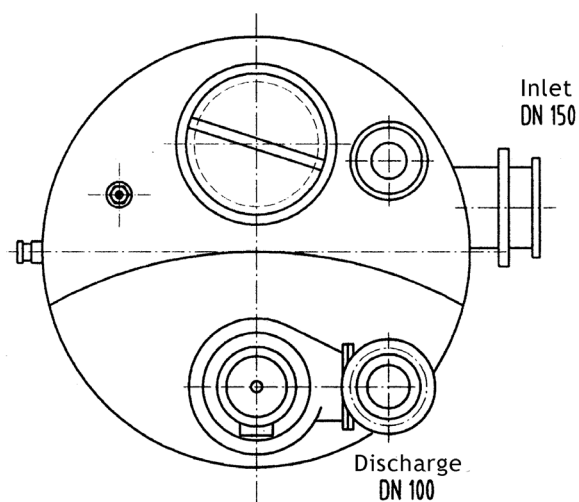
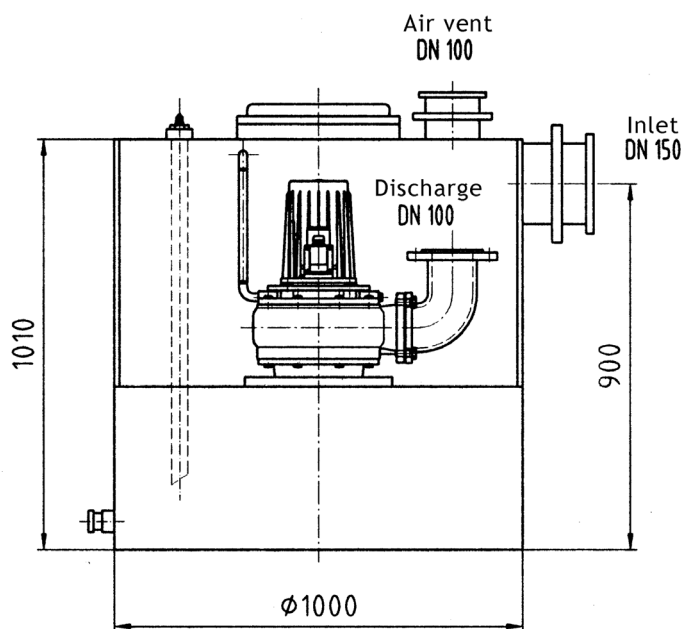

Trojan 1000 Channel Dual

