

## ELECTRIC SUBMERSIBLE PUMPS SEMISOM/80

Electric pumps for professional applications to convey sewage water, entirely designed and manufactured in our Italian facility.



### APPLICATION

To convey waste and sewage water from septic tanks;

To drain rain water;

To pump liquids containing solids, filaments and sewage keeping its biological process unchanged (4 poles version).

### PERFORMANCE RANGE

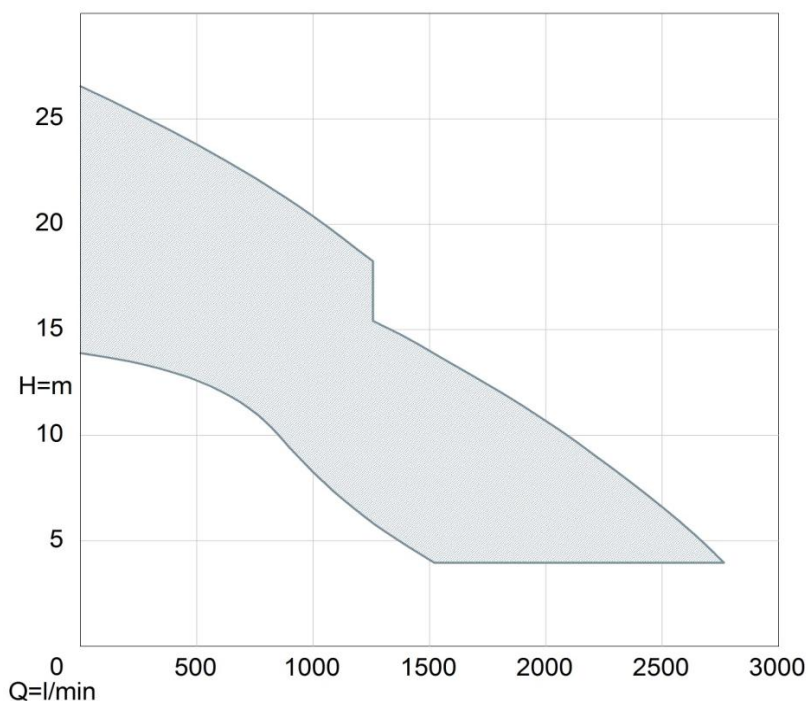

# ELECTRIC SUBMERSIBLE PUMPS SEMISOM/80

## TYPE OF THE ELECTRIC PUMP: SEMISOM 1775/80



### TECHNICAL CHARACTERISTICS

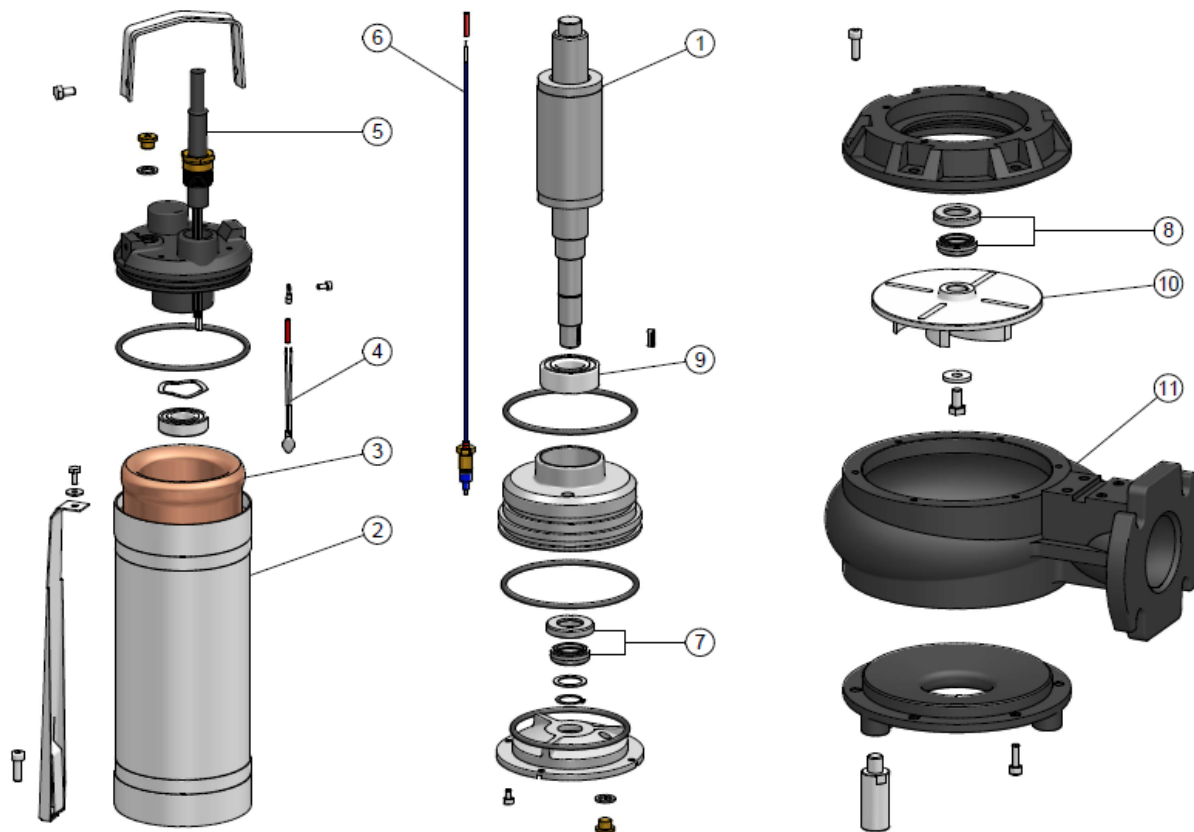

Shafts with grinded spots for ball bearings and mechanical seals (1). Thick external casing obtained from wire drawn tubes, with brushed spots for the mechanical seals (2).

Three-phase electric asynchronous rewindable motors with short-circuit rotor, coolant filled so to assure low working temperatures. Windings with phase insulators to protect the motor from power peaks, as a guarantee of a highly-trustworthy product (3). Micro thermostat to protect the motor from high temperatures to be wired to the protection/control panel (4). Resin-insulated cable kit to prevent penetration of water inside the motor (5).

Mechanical seal in the first chamber in graphite and alumina (7). Probe to detect water ingress in the oil chamber between the two mechanical seals to be wired to the protection/control panel (6). Silicon carbide and alumina external mechanical seal (8).

Double-row lubricated and over-dimensioned ball bearings to grant a long life (9).

High-efficiency impellers designed to be interchangeable with pumps of the same power (10).

Volute with Flygt-compatible guide rail claw (11).

### MATERIALS

Tie rods, handle, motor casing, bolts and nuts	Stainless steel AISI 304
Shaft	Stainless Steel AISI 420B
Cover and pump body	Mechanical cast iron EN GJL-250
Impeller	Mechanical cast iron EN GJL-250
Feet	Stainless steel AISI 304
External mechanical seal	Silicon carbide and Alumina
Mechanical seal in the first chamber	Graphite e alumina
Elastomers	Rubber NBR
Cable	PBS8-F AD8



# ELECTRIC SUBMERSIBLE PUMPS SEMISOM/80

## TYPE OF THE ELECTRIC PUMP: SEMISOM 1775/80

### HYDRAULIC CHARACTERISTICS

Type of impeller	Vortex
Inlet nominal diameter (mm)	74
Outlet nominal diameter (mm)	80
Solid passage Ø (mm)	74

### APPLICATION FEATURES

Protection degree	IP68
Duty	Continuous (S1)
Max immersion depth (m)	20
Max number of starts per hour	30
Max temperature of the liquid pumped (°C)	50
PH of the liquid pumped	6 - 10
Density of the liquid pumped (kg/dm³)	<1,1
Suitable for inverter drive	YES

### PROTECTIONS

Thermal protection	YES
Detection of water ingress	YES

### ELECTRICAL CHARACTERISTICS

Power (V)	400
No. of Phases	3
Frequency (Hz)	50
Insulation class	F
Nominal Speed (1/min)	2850
Nominal Power of the motor (kW)	5,5
Max absorbed power P1 (kW)	6,8
Start current (A)	49
Max. current (A)	11,9
No. of Poles	2

	Load		
	4/4	3/4	1/2
Power factor	0,83	0,76	0,69
Motor efficiency	81,8%	81,5%	79,7%

### PERFORMANCE CURVES

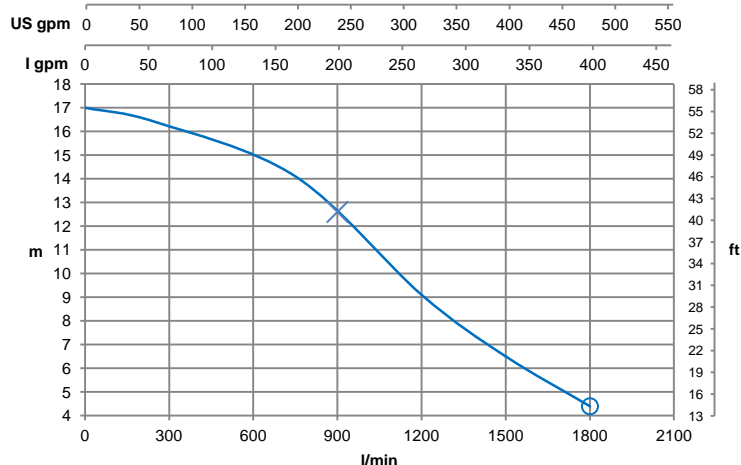

**X = MAX. EFFICIENCY  
(Best Efficiency Point)**

Total efficiency $\eta_t$ (%)	35
Hydraulic efficiency $\eta_i$ (%)	42
Absorbed power P1 (kW)	5,3
Hydraulic power P2 (kW)	4,4
Head (m)	12,6
Flow (l/min)	900

### LIMITS

Flow max. (l/min)	1800
Head max. (m)	17
O = Minimum Head (m)	4,4

—  $\eta_i$  Hydraulic efficiency  
—  $\eta_t$  Total efficiency

— P1 Absorbed power  
— P2 Hydraulic power

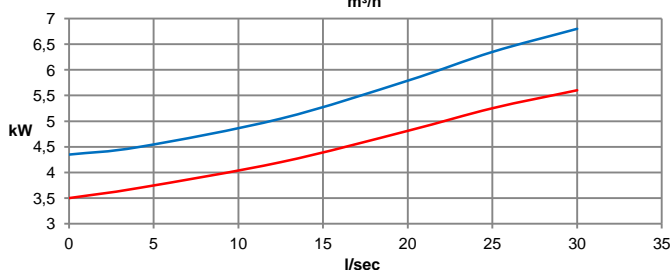
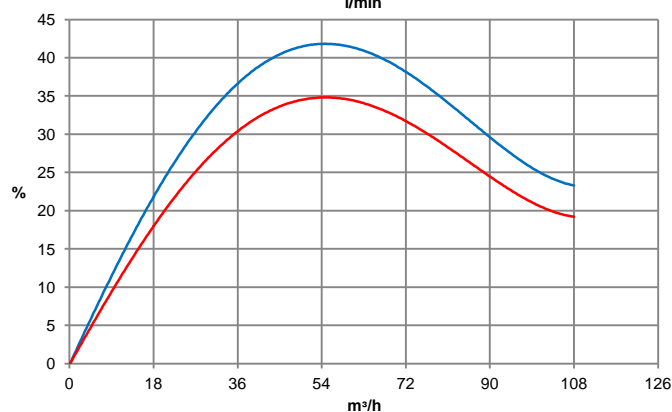

# ELECTRIC SUBMERSIBLE PUMPS SEMISOM/80

## TYPE OF THE ELECTRIC PUMP: SEMISOM 1775/80



### DIMENSIONS AND WEIGHTS

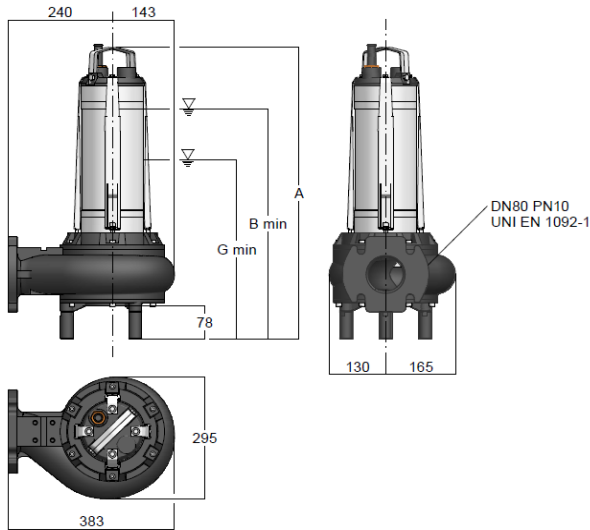

#### STANDARD VERSION

G = Minimum STOP level in case of automatic control (mm)	438,0
B = Minimum level of liquid in case of continuous duty (mm)	588,0
A = Total height (mm)	733,0
WEIGHT (kg)	69,0
Length of cable (m)	10,0

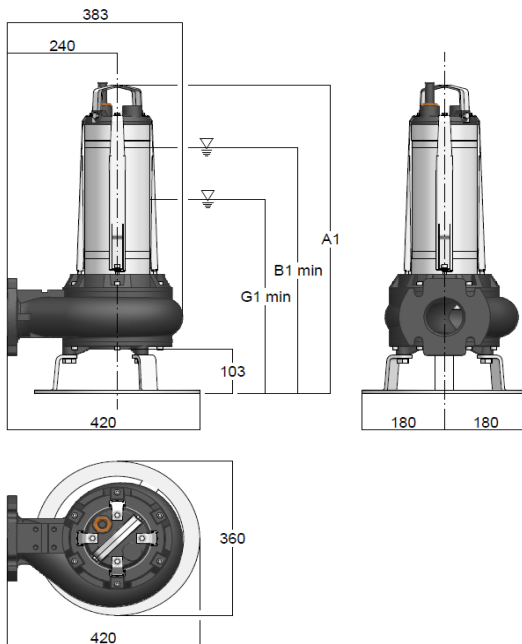
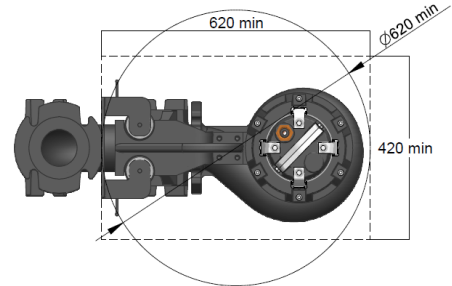
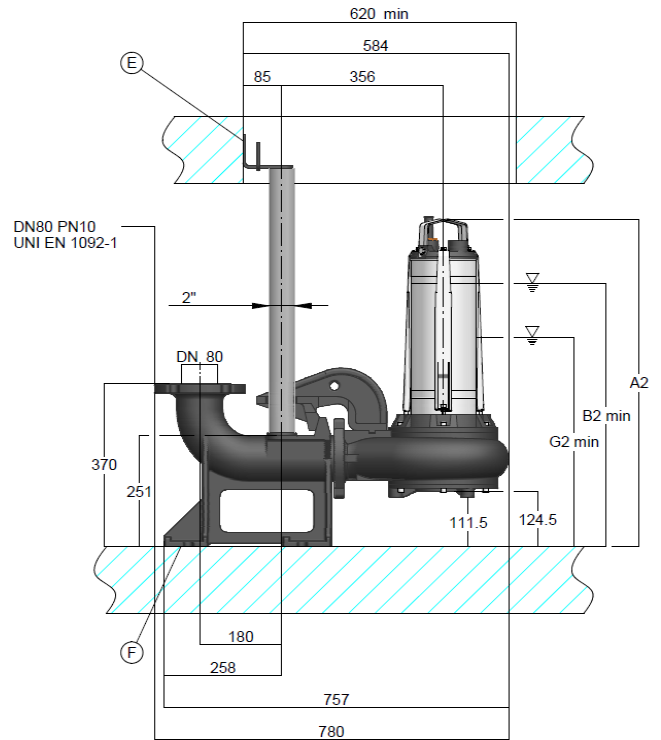

#### VERSION WITH PUMP STAND

G1 = Minimum STOP level in case of automatic control (mm)	463,0
B1 = Minimum level of liquid in case of continuous duty (mm)	613,0
A1 = Total height (mm)	758,0

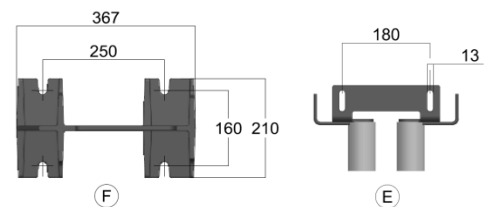

#### VERSION WITH GUIDE RAIL KIT

G2 = Minimum STOP level in case of automatic control (mm)	484,5
B2 = Minimum level of liquid in case of continuous duty (mm)	634,5
A2 = Total height (mm)	779,5

# ELECTRIC SUBMERSIBLE PUMPS SEMISOM/80

## TYPE OF THE ELECTRIC PUMP: SEMISOM 1775/80



### ACCESSORIES

Code Description

05135005 THREADED FLANGE DN 3" PN 16

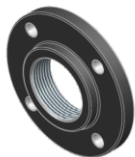

03720005 PUMP STAND IN GALVANISED STEEL

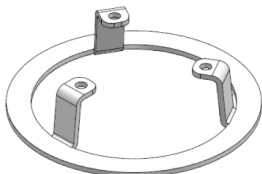

05430110 NON-RETURN FLANGED BALL VALVE DN80 PN16



04105053 GUIDE RAIL KIT

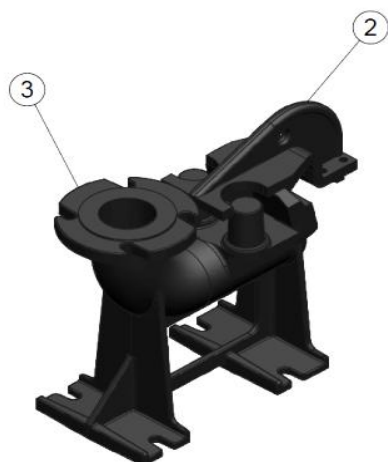

04105081 1. TOP BRACKET

04105070 2. CLAW

04105090 3. STOOL

# ELECTRIC SUBMERSIBLE PUMPS SEMISOM/80

## TYPE OF THE ELECTRIC PUMP: SEMISOM 1775/80



### ACCESSORIES

Code Description

02082020 DIRECT-ON-LINE STARTER ATS 100 TO CONTROL ONE SINGLE ELECTRIC PUMP



### GENERAL CHARACTERISTICS

Power (V)	400
No. of Phase	3
Frequency (Hz)	50
Degree of protection	IP55
Ambient temperature (°C)	-5/+40
Nominal Current (A)	12-18

### CONTROL

Via a HAND-OFF-AUTO selector switch  
In AUTO via RUN-STOP float switches

### CONSTRUCTION

Opening interlocked  
Transformer 230-400 V  
Contactor 24 V  
Thermal relay for motor protection  
Relay to control motor overheating  
Set of fuses for motor protection and on auxiliary circuit  
Electronic control to check any ingress of water in the first chamber  
HAND-OFF-AUTO selector switch;  
Indicator lights for: power - run - thermal cut-out - overheating cut-out - cut-out in case of water ingress in the first chamber - max. level alarm  
Steel-sheet control panel  
Dimensions: 300x400x150mm  
Facility for 24 V AC alarm device

02082120 DIRECT-ON-LINE STARTER AT2S 100 TO CONTROL TWO ELECTRIC PUMPS



### GENERAL CHARACTERISTICS

Power (V)	400
No. of Phase	3
Frequency (Hz)	50
Degree of protection	IP55
Ambient Temperature (°C)	-5/+40
Nominal Current (A)	12-18

### CONTROL

Via a HAND-OFF-AUTO selector switch  
In AUTO via float switches  
(alternative and contemporaneous control of two electric pumps)

### CONSTRUCTION

Opening interlocked  
Transformer 230-400 V  
Contactors 24 V  
Thermal relays for motor protection  
Relays to control overheating of the motors  
Set of fuses for motor protection and on auxiliary circuit  
Electronic circuit for alternative and contemporaneous control of the electric pumps  
Electronic control to check any ingress of water in the first chambers  
HAND-OFF-AUTO selector switches  
Indicator lights for: on-line - pump 1 - pump 2 - thermal cut-out - cut-out for motor overheating - cut-out in case of water ingress in the first chamber  
NORMALLY OPEN contact facility for power failure alarm device;  
Steel-sheet control panel  
Dimensions: 400x600x200 mm