



## Elettropompe sommergibili

### Girante Monocanale

#### Serie FMc 75

1,85 - 5,5 kW

Mandata

DN 80

## Submersible pumps

### Single-channel impeller

#### Series FMc 75

1,85 - 5,5 kW

Discharge size

DN 80

## Погружные электронасосы

### С одноканальным рабочим колесом

#### Серия FMc 75

1,85 - 5,5 kW

выходное отверстие

DN 80

## Electropompes submersibles

### Roue monocanal

#### Série FMc 75

1,85 - 5,5 kW

Diam. refoulement

DN 80

## Bombas sumergibles

### Turbina monocanal

#### Modelo FMc 75

1,85 - 5,5 kW

Diámetro impulsión

DN 80

## Bombas eléctricas submergíveis

### Giratória mono-canal

#### Série FMc 75

1,85 - 5,5 kW

Diâmetro boca

DN 80

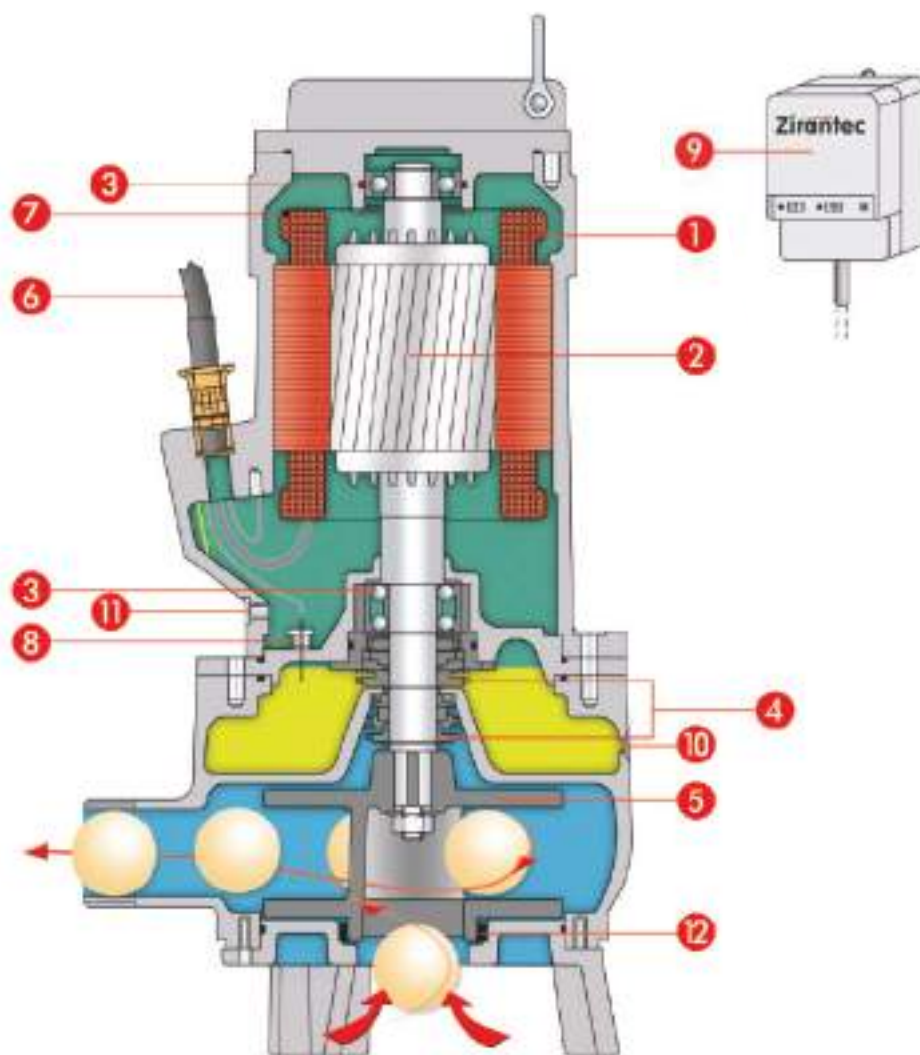

1. Motore completamente sommerso a tenuta stagna  
Classe di isolamento H. Grado di protezione IP68  
Giri: 2850 al min<sup>-1</sup>  
Votaggio: trifase 3x380/415V-50 Hz  
Altri voltaggi e frequenze a richiesta
2. Albero in acciaio AISI 420
3. Cuscinetti prelubrificati lunga vita
4. Doppia tenuta meccanica in camera d'olio  
Tenuta inferiore: carburo di silicio/carburo di silicio  
Tenuta superiore: grafite/allumina
5. Girante monocanale
6. Cavo H07RNF
7. Protezione termica incorporata nell'avvolgimento (optional)
8. Sonda camera olio
9. AET-quadro elettrico
10. Ispezione olio
11. Controllo tenuta stagna motore
12. Anello usura in bronzo

1. Fully submersible pressure tight electric motor  
Insulation class H. Protection degree IP 68  
Speed: 2850 rpm. Voltage: three-phase  
3x380/415V-50 Hz.  
Different voltage and frequency on request.
2. Shaft in stainless steel AISI 420
3. Pre-lubricated long-life bearings
4. Double mechanical seal in oil chamber  
Water side: silicon carbide/silicon carbide  
Motor side: graphite/alumina
5. Single-channel impeller
6. Cable H07RNF
7. Thermal protection embedded in winding (optional)
8. Oil chamber probe (optional)
9. AET- electrical gear
10. Oil inspection plug
11. Hole for the motor watertightness control
12. Bronze wear ring

1. Герметичный полностью погружной двигатель.  
Класс изоляции H. Класс защиты IP68.  
Скорость вращения: 2850 об./мин.  
Напряжение: трехфазное 3x380/415 В 50 Гц.  
Другие напряжения и частота под заказ.
2. Вал из нержавеющей стали AISI 420
3. Долгосрочные подшипники со смазкой
4. Двойное мех. уплотнение в масляной камере  
С гидравлической стороны: карбид кремния/ карбид кремния  
Со стороны двигателя: графит/оксид алюминия
5. Одноканальное рабочее колесо
6. Кабель H07RNF
7. Теплозащита, встроенная в обмотку (опция)
8. Датчик в масляной камере (опция)
9. Пульт управления AET
10. Окошко для контроля масла
11. Контроль герметичности двигателя
12. Расходное кольцо из бронзы

1. Moteur entièrement submergé étanche à l'eau  
Classe d'isolation H. indice de protection IP 68  
Vitesse de rotation: 2850 tr/mn  
Bobinage tri: 3x380/415V Fréquence: 50 Hz  
Autres tensions et fréquences sur demande.
2. Arbre moteur en acier AISI 420
3. Roulements surdimensionnés lubrifiés à vie
4. Double garniture mécanique en chambre huile  
Garniture inférieure: Carbure de silicium/Carbure de silicium  
Garniture supérieure: graphite/alumine
5. Roue monocanal
6. Cable H07RNF
7. Protection thermique intégré dans le bobinage (en option)
8. Détecteur d'infiltration dans la chambre à huile
9. Coffret électrique de commande AET
10. Inspection de l'huile
11. Contrôle moteur étanche à l'eau
12. Anneau usure en bronze

1. Motor completamente sumergido estanco  
Clase de aislamiento H. Protección IP-68.  
Velocidad: 2850 rpm/min<sup>-1</sup>  
Voltaje: trifásico 3 x 380/415V 50 Hz  
Otros voltajes y frecuencias a demanda.
2. Eje Acero inoxidable AISI 420
3. Cojinetes sobredimensionados lubricados indefinitamente
4. Doble cierre mecánico en cámara de aceite  
Carburo de silicio/Carburo de silicio en el lado agua  
Grafito/Acero templado en el lado motor
5. Impulsor monocanal
6. Cable H07RNF
7. Protector térmico en el bobinado (opcional)
8. Detector de infiltraciones en la cámara de aceite
9. AET cCuadros eléctricos
10. Inspección aceite
11. Control de motor estanco
12. Anillo de desgaste de bronce

1. Motor totalmente submerso estanco  
Isolamentos em classe H. Grau de proteção IP 68  
rpm: 2850  
Tensão: trifásica 3x380/415V-50  
Outras tensões e frequências a pedido.
2. Eixo em aço AISI 420
3. Chumaceiras sobredimensionados isentas de manutenção
4. Duplo contenção na câmara óleo  
Contenção inferior: carboneto de silício  
Contenção superior: grafito/allumina
5. Giratória mono-canal
6. Cabo H07RNF
7. Proteção térmica nas bobines (opcional)
8. Detector da infiltração na câmara óleo (opcional)
9. AET painel elétrico
10. Inspeção de óleo
11. Controle motor estanco
12. Anel de desgaste de bronze

CODICE IDENTIFICAZIONE PRODOTTO  
PRODUCTS IDENTIFICATION CODE

ИДЕНТИФИКАЦИОННЫЙ КОД ПРОДУКТА  
CODE D'IDENTIFICATION DU PRODUIT

CÓDIGO DE IDENTIFICACIÓN DE PRODUCTO  
CÓDIGO DE IDENTIFICAÇÃO DO PRODUTO

<b>F</b>	<b>Mc</b>	<b>75.</b>	<b>1,85</b>	<b>-</b>	<b>2</b>	<b>/</b>	<b>114</b>
<ul style="list-style-type: none"> <li>• PRODUZIONE FIPS</li> <li>• FIPS PRODUCTION</li> <li>• ПРОИЗВОДСТВО FIPS</li> <li>• PRODUCTION FIPS</li> <li>• PRODUCCIÓN DE FIPS</li> <li>• PRODUÇÃO FIPS</li> </ul>	<ul style="list-style-type: none"> <li>• GIRANTE</li> <li>• IMPELLER</li> <li>• РАБОЧЕЕ КОЛЕСО</li> <li>• ROUÉ</li> <li>• IMPULSOR</li> <li>• GIRATÓRIA</li> </ul>	<ul style="list-style-type: none"> <li>• NOME SERIE</li> <li>• SERIES NAME</li> <li>• СЕРИЯ</li> <li>• NOM DE LA SÉRIE</li> <li>• NOMBRE DE LA SERIE</li> <li>• NOME DA SÉRIE</li> </ul>	<ul style="list-style-type: none"> <li>• P2 POTENZA NOMINALE MOTORE</li> <li>• P2 MOTOR NOMINAL POWER</li> <li>• НОМИНАЛЬНАЯ МОЩНОСТЬ ДВИГАТЕЛЯ</li> <li>• PUISSANCE NOMINALE MOTEUR</li> <li>• POTENCIA NOMINAL DEL MOTOR</li> <li>• POTÊNCIA NOMINAL DO MOTOR</li> </ul>		<ul style="list-style-type: none"> <li>• GIRI MOTORE</li> <li>• NO. OF POLES (MOTOR SPEED)</li> <li>• КОЛ-ВО ОБОРОТОВ ДВИГАТЕЛЯ</li> <li>• RPM</li> <li>• RPM</li> <li>• RPM</li> </ul>		<ul style="list-style-type: none"> <li>• DIAMETRO GIRANTE</li> <li>• IMPELLER DIAMETER</li> <li>• ДИАМЕТР РАБОЧЕГО КОЛЕСА</li> <li>• DIAMÈTRE DE LA ROUE</li> <li>• DIÁMETRO TURBINA</li> <li>• DIÁMETRO GIRATÓRIA</li> </ul>

# FMc 75 - 2



CURVE DI PRESTAZIONE  
PERFORMANCE CURVES

ХАРАКТЕРИСТИЧЕСКИЕ КРИВЫЕ  
COURBE CARACTÉRISTIQUE

CURVA CARACTERÍSTICA  
CURVA CARACTERÍSTICA

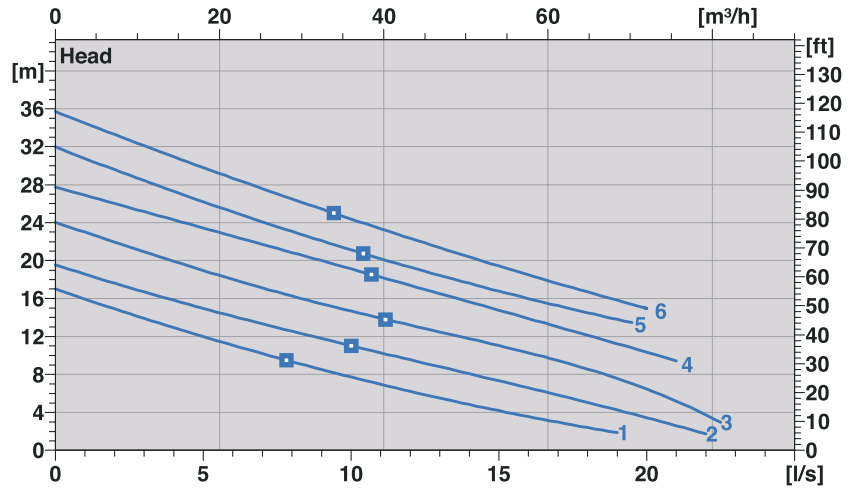

CARATTERISTICHE GENERALI - GENERAL FEATURES - ОСНОВНЫЕ ХАРАКТЕРИСТИКИ CARACTERÍSTICAS GENERALES - CARACTERÍSTICA GERAIS									PRESTAZIONI - PERFORMANCES - РАБОЧИЕ ПАРАМЕТРЫ - PERFORMANCES - RENDIMENTO - EXECUÇÃO										
Nr	Modello - Type	P1 kW	P2 kW	Volt	Amp	Giri rpm	DN	Ø mm	l/sec m³/h	0	3	6	9	12	15	18	21	22	
1	FMc 75.1,85-2/114	2,2	1,85	3X400	4	2850	80	50		H m	10,8	22	32	43,2	54	64,8	75,6	79,2	79,2
2	FMc 75.2,2-2/124	2,6	2,2	3X400	5,2	2850	80	50	17		14	11	8,4	6,3	4,3	2,4			
3	FMc 75.3-2/128	3,7	3	3X400	6,8	2850	80	50	19,5		16,7	14,2	11,7	9,5	7,3	5,2	2,6	1,7	
4	FMc 75.4-2/138	5	4	3X400	8,6	2850	80	50	24		20,8	18	15,4	13,2	11,1	8,6	5,1	3,6	
5	FMc 75.5-2/145	6	5	3X400	9,8	2850	80	50	27,7		25,3	22,5	20	17,3	14,9	12,1	9		
6	FMc 75.5,5-2/152	6,2	5,5	3x400 Δ	10	2850	80	50	32		28,4	25	22	19,4	16,9	14,3			
										36	31,9	28,3	25,5	22,5	19,6	17			

DIMENSIONI DI INSTALLAZIONE - INSTALLATION SIZES - УСТАНОВОЧНЫЕ РАЗМЕРЫ DIMENSÕES DE INSTALAÇÃO - DIMENSÕES DE INSTALAÇÃO				
Nr	Modello - Type	A max	V	KG
1	FMc 75.1,85-2/114	507	80N	42
2	FMc 75.2,2-2/124	507	80N	44
3	FMc 75.3-2/128	513	80N	45
4	FMc 75.4-2/138	513	80N	49
5	FMc 75.5-2/145	563	80N	51
6	FMc 75.5,5-2/152	563	80N	57

DIMENSIONI D'INGOMBRO  
DIMENSION DRAWINGS  
ГАБАРИТНЫЕ ЧЕРТЕЖИ  
DIMENSIONS D'ENCOMBREMENT  
DIMENSIONES TOTALES  
DIMENSÕES GLOBAIS

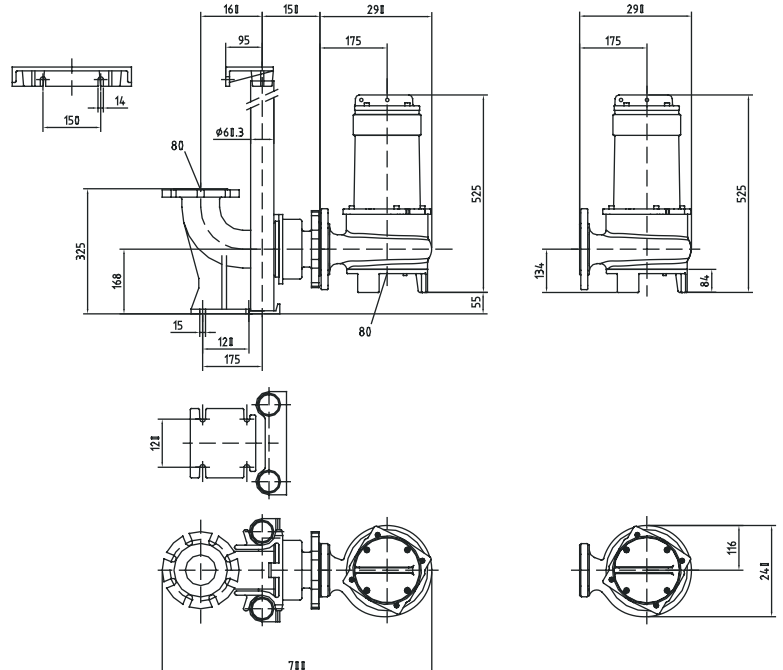



## Elettropompe sommergibili

### Girante Monocanale

#### Serie FMc 80 - 100 - 150

1,6 - 34 kW

[Mandata](#)

DN 80 - 100 - 150

## Submersible pumps

### Single-channel impeller

#### Series FMc 80 - 100 - 150

1,6 - 34 kW

[Discharge size](#)

DN 80 - 100 - 150

## Погружные электронасосы

### С одноканальным рабочим колесом

#### Серия FMc 80 - 100 - 150

1,6 - 34 kW

[выходное отверстие](#)

DN 80 - 100 - 150

## Electropompes submersibles

### Roue monocanal

#### Série FMc 80 - 100 - 150

1,6 - 34 kW

[Diam. refoulement](#)

DN 80 - 100 - 150

## Bombas sumergibles

### Turbina monocanal

#### Modelo FMc 80 - 100 - 150

1,6 - 34 kW

[Diámetro impulsión](#)

DN 80 - 100 - 150

## Bombas eléctricas submergíveis

### Giratória mono-canal

#### Série FMc 80 - 100 - 150

1,6 - 34 kW

[Diâmetro boca](#)

DN 80 - 100 - 150

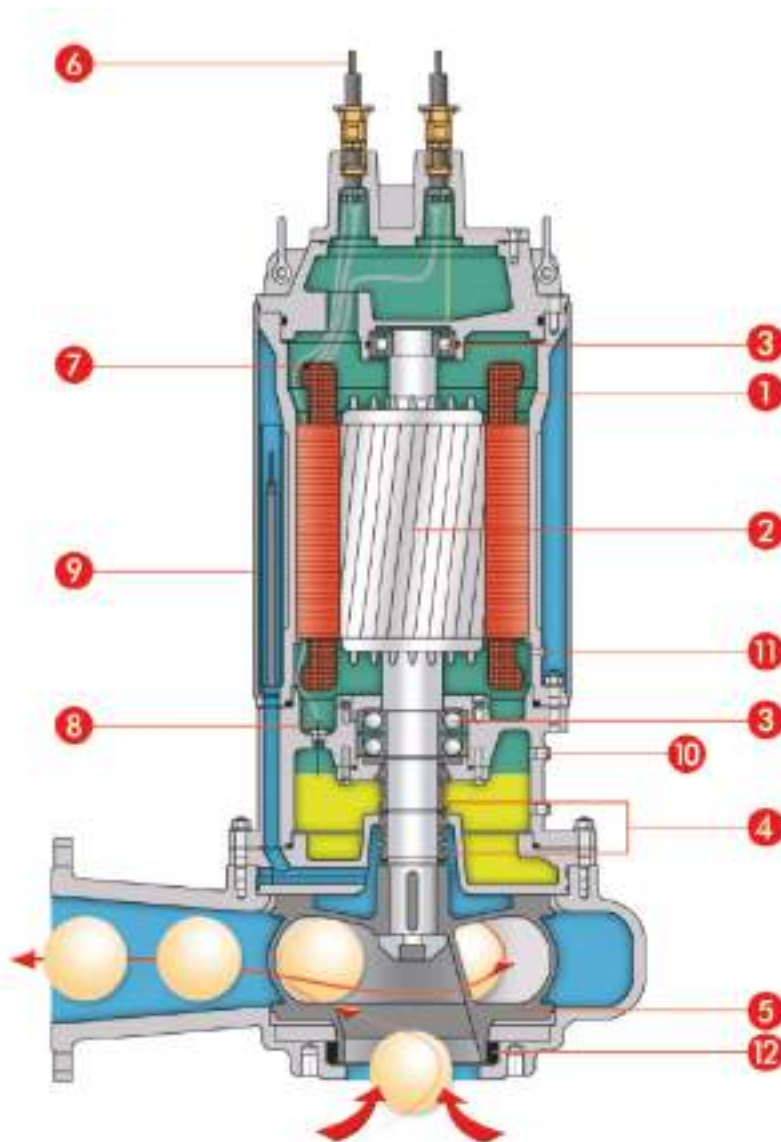

1. Motore completamente sommerso a tenuta stagna  
Classe di isolamento H. Grado di protezione IP68  
Giri: 960 - 1450 - 2850 al min<sup>-1</sup>  
Vtaggio: trifase 3x380/415V-50 Hz  
Altri voltaggi e frequenze a richiesta
2. Albero in acciaio AISI 420
3. Cuscinetti prelubrificati lunga vita (50.000 ore)
4. Doppia tenuta meccanica in camera d'olio  
Tenuta inferiore: carburo di silicio/carburo di silicio  
Tenuta superiore: carburo di silicio/carburo di silicio
5. Girante monocanale chiusa
6. Cavo H07RNF
7. Protezione termica incorporata nell'avvolgimento (optional)
8. Sonda camera olio
9. Camicia di raffreddamento
10. Ispezione olio
11. Controllo tenuta stagna motore
12. Anello usura in bronzo

1. Fully submersible pressure tight electric motor  
Insulation class H. Protection degree IP 68  
Speed: 960 - 1450 - 2850 rpm. Voltage: three-phase  
3x380/415V-50 Hz  
Different voltage and frequency on request.
2. Shaft in stainless steel AISI 420
3. Pre-lubricated long-life bearings (50.000 hours)
4. Double mechanical seal in oil chamber  
Water side: silicon carbide/silicon carbide  
Motor side: silicon carbide/silicon carbide
5. Closed single-channel impeller
6. Cable H07RNF
7. Thermal protection embedded in winding (optional)
8. Oil chamber probe
9. Cooling jacket (optional)
10. Oil inspection plug
11. Hole for the motor watertightness control
12. Bronze wear ring

- Герметичный полностью погружной двигатель. Класс изоляции H. Класс защиты IP68. Скорость вращения: 960 - 1450 - 2850 об./мин. Напряжение: трехфазное 3x380/415 В 50 Гц. Другие напряжения и частота под заказ.
- Вал из нержавеющей стали AISI 420
- Долгосрочные подшипники со смазкой (50.000 часов)
- Двойное мех. уплотнение в масляной камере С гидравлической стороны: карбид кремния/ карбид кремния Со стороны двигателя: карбид кремния/ карбид кремния
- Закрытое одноканальное рабочее колесо
- Кабель H07RNF
- Теплозащита в обмотке (опция)
- Датчик в масляной камере
- Охлаждающая рубашка (опция)
- Окошко для контроля масла
- Контроль герметичности двигателя
- Расходное кольцо из бронзы

- Moteur entièrement submergé étanche à l'eau Classe d'isolation H. indice de protection IP 68 Vitesse de rotation: 960 - 1450 - 2850 tr/mn Bobinage tri: 3x380/415V-50 Hz Fréquence: 50 Hz Autres tensions et fréquences sur demande.
- Arbre moteur en acier AISI 420
- Roulements surdimensionnés lubrifiés à vie (50.000 heures)
- Double garniture mécanique en chambre huile Garniture inférieure: Carbure de silicium/Carbure de silicium Garniture supérieure: Carbure de silicium/Carbure de silicium
- Roue monocanal fermé
- Cable H07RNF
- Protection thermique intégré dans le bobinage (en option)
- Détecteur d'infiltration dans la chambre à huile
- Chemise de refroidissement
- Inspection de l'huile
- Contrôle moteur étanche à l'eau
- Anneau usure en bronze

- Motor completamente sumergido estanco Clase de aislamiento H. Protección IP-68. Velocidad: 960 - 1450 - 2850 rpm/min<sup>-1</sup> Voltaje: trifásico 3x380/415V-50 Hz -50 Hz Otros voltajes y frecuencias a demanda.
- Eje Acero inoxidable AISI 420
- Cojinetes sobredimensionados lubricados indefinidamente (50.000 horas)
- Doble cierre mecánico en cámara de aceite Carburo de silicio/Carburo de silicio en el lado agua. Carburo de silicio/Carburo de silicio en el lado motor
- Impulsor monocanal cerrado
- Cable H07RNF
- Protector térmico en el bobinado (opcional)
- Detector de infiltraciones en la cámara de aceite
- Camisa de refrigeración (opcional)
- Inspección aceite
- Control de motor estanco
- Anillo de desgaste de bronce

- Motor totalmente submerso estanco Isolamentos em classe H. Grau de proteção IP 68 rpm: 960 - 1450 - 2850 Tensão: trifásica 3x380/415V-50 Hz -50 Hz Outras tensões e frequências a pedido.
- Eixo em aço AISI 420
- Chumaceiras sobredimensionados isentas de manutenção (50.000 horas)
- Duplo contenção na câmara óleo Contenção inferior: carboneto de silício Contenção superior: carboneto de silício
- Giratória mono-canal fechada
- Cabo H07RNF
- Proteção térmica nas bobinas (opcional)
- Detector da infiltração na câmara óleo
- Camisa de resfriamento
- Inspeção de óleo
- Controle motor estanco
- Anel de desgaste de bronze

CODICE IDENTIFICAZIONE PRODOTTO  
PRODUCTS IDENTIFICATION CODE

CODE D'IDENTIFICATION DU PRODUIT

CÓDIGO DE IDENTIFICACIÓN DE PRODUCTO  
CÓDIGO DE IDENTIFICAÇÃO DO PRODUTO

F	Mc	80.	1,6	-	4	/	191
• PRODUZIONE FIPS	• GIRANTE	• NOME SERIE	• P2 POTENZA NOMINALE MOTORE		• GIRI MOTORE		• DIAMETRO GIRANTE
• FIPS PRODUCTION	• IMPELLER	• SERIES NAME	• P2 MOTOR NOMINAL POWER		• NO. OF POLES (MOTOR SPEED)		• IMPELLER DIAMETER
• ПРОИЗВОДСТВО FIPS	• РАБОЧЕЕ КОЛЕСО	• СЕРИЯ	• НОМИНАЛЬНАЯ МОЩНОСТЬ ДВИГАТЕЛЯ		• КОЛ-ВО ОБОРОТОВ ДВИГАТЕЛЯ		• ДИАМЕТР РАБОЧЕГО КОЛЕСА
• PRODUCTION FIPS	• ROUÉ	• NOM DE LA SÉRIE	• PUISSANCE NOMINALE MOTEUR		• RPM		• DIAMÈTRE DE LA ROUE
• PRODUCCIÓN DE FIPS	• IMPULSOR	• NOMBRE DE LA SERIE	• POTENCIA NOMINAL DEL MOTOR		• RPM		• DIÁMETRO TURBINA
• PRODUÇÃO FIPS	• GIRATÓRIA	• NOME DA SÉRIE	• POTÊNCIA NOMINAL DO MOTOR		• RPM		• DIÁMETRO GIRATÓRIA

# FMc 80 - 4



CURVE DI PRESTAZIONE  
PERFORMANCE CURVES

ХАРАКТЕРИСТИЧЕСКИЕ КРИВЫЕ  
COURBE CARACTÉRISTIQUE

CURVA CARACTERÍSTICA  
CURVA CARACTERÍSTICA

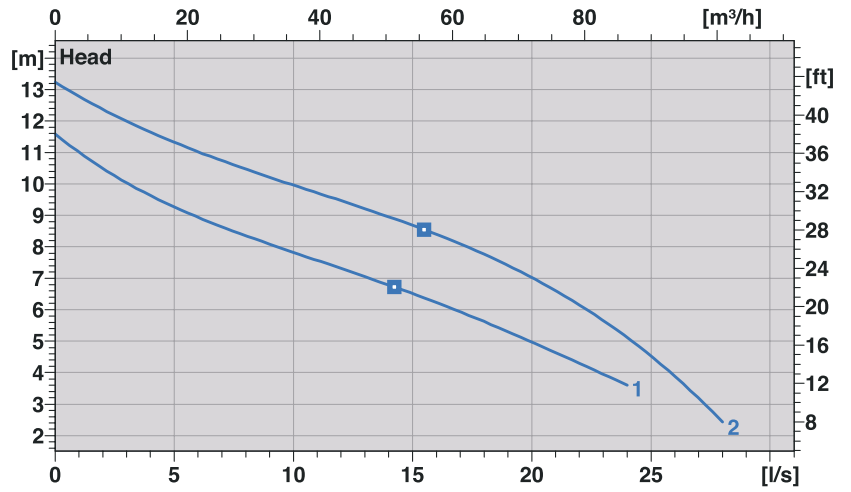

CARATTERISTICHE GENERALI - GENERAL FEATURES - ОСНОВНЫЕ ХАРАКТЕРИСТИКИ CARACTÉRISTIQUES GÉNÉRALES - CARACTERÍSTICAS GENERALES - CARACTERÍSTICA GERAIS											PRESTAZIONI - PERFORMANCES - РАБОЧИЕ ПАРАМЕТРЫ PERFORMANCES - RENDIMIENTO - EXECUÇÃO							
Nr	Modello - Type	P1 kW	P2 kW	Volt	Amp	Giri rpm	DN	Ø mm	V	KG	I/sec m³/h	0	5	10	15	20	25	30
1	FMc 80.1,6-4/191	1,9	1,6	3X400	4	1450	80	73	80N	62	H	11,6	9,3	7,8	6,5	4,9		
2	FMc 80.2,2-4/212	2,9	2,2	3X400	5,4	1450	80	73	80N	63	m	13,2	11,3	9,8	8,5	6,7	4,6	

DIMENSIONI D'INGOMBRO  
DIMENSION DRAWINGS  
ГАБАРИТНЫЕ ЧЕРТЕЖИ  
DIMENSIONS D'ENCOMBREMENT  
DIMENSIONS TOTALES  
DIMENSÕES GLOBAIS

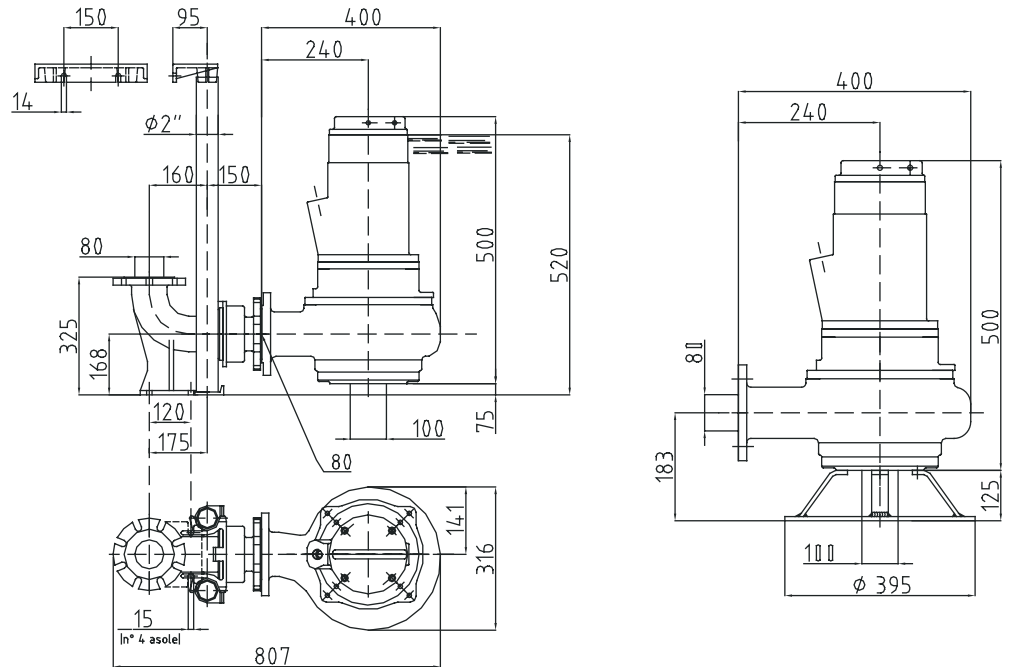



# FMc 80 - 4



CURVE DI PRESTAZIONE  
PERFORMANCE CURVES

ХАРАКТЕРИСТИЧЕСКИЕ КРИВЫЕ  
COURBE CARACTÉRISTIQUE

CURVA CARACTERÍSTICA  
CURVA CARACTERÍSTICA

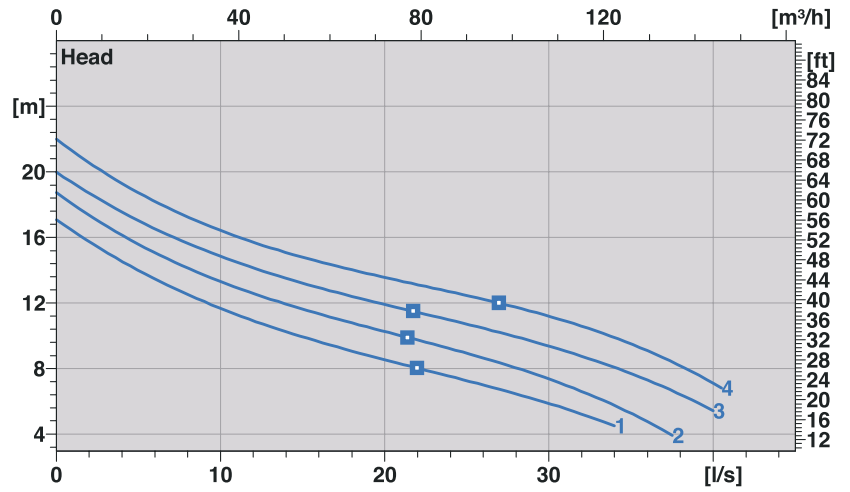

CARATTERISTICHE GENERALI - GENERAL FEATURES - ОСНОВНЫЕ ХАРАКТЕРИСТИКИ									PRESTAZIONI - PERFORMANCES - РАБОЧИЕ ПАРАМЕТРЫ - PERFORMANCES - RENDIMENTO - EXECUÇÃO											
Nr	Modello - Type	P1 kW	P2 kW	Volt	Amp	Giri rpm	DN	Ø mm	l/sec	0	5	10	15	20	25	30	35	40	45	
									m³/h	0	18	36	54	72	90	108	126	144	162	
1	FMc 80.3,5-4/218	3,8	3,5	3X400	6,6	1450	80	80	H	17	14,2	11,9	10	8,4	7	5,5				
2	FMc 80.4,2-4/228	5	4,2	3X400	9,9	1450	80	80	m	18,9	15,4	13,2	11,7	10,4	9	7,3	5,2			
3	FMc 80.5-4/235	6	5	3X400 Δ	11	1450	80	80		20,2	16,8	14,7	13,3	12,1	10,7	9,1	7,3			
4	FMc 80.6,5-4/250	7,6	6,5	3X400 Δ	13	1450	80	80		22	18,7	16,5	14,9	13,6	12,3	10,8	9,3	7,3		

DIMENSIONI DI INSTALLAZIONE - INSTALLATION SIZES - УСТАНОВОЧНЫЕ РАЗМЕРЫ - DIMENSIONS D'INSTALLATION - DIMENSIONES DE INSTALACIÓN - DIMENSÕES DE INSTALAÇÃO																
Nr	Modello - Type	A max	B	B1	C	C1	D	E	F1	F2	G	P2	P4	DN1	V	KG
1	FMc 80.3,5-4/218	520	397	280	316	141	807	75	90	183	320		540	80	80N	66
2	FMc 80.4,2-4/228	646	459	280	363	165	869	49	125	244	395	480	680	100	80N	102
3	FMc 80.5-4/235	646	459	280	363	165	869	49	125	244	395	480	680	100	80N	105
4	FMc 80.6,5-4/250	646	459	280	363	165	869	49	125	244	395	480	680	100	80N	108

DIMENSIONI D'INGOMBRO  
DIMENSION DRAWINGS  
ГАБАРИТНЫЕ ЧЕРТЕЖИ  
DIMENSIONS D'ENCOMBREMENT  
DIMENSIONES TOTALES  
DIMENSÕES GLOBAIS

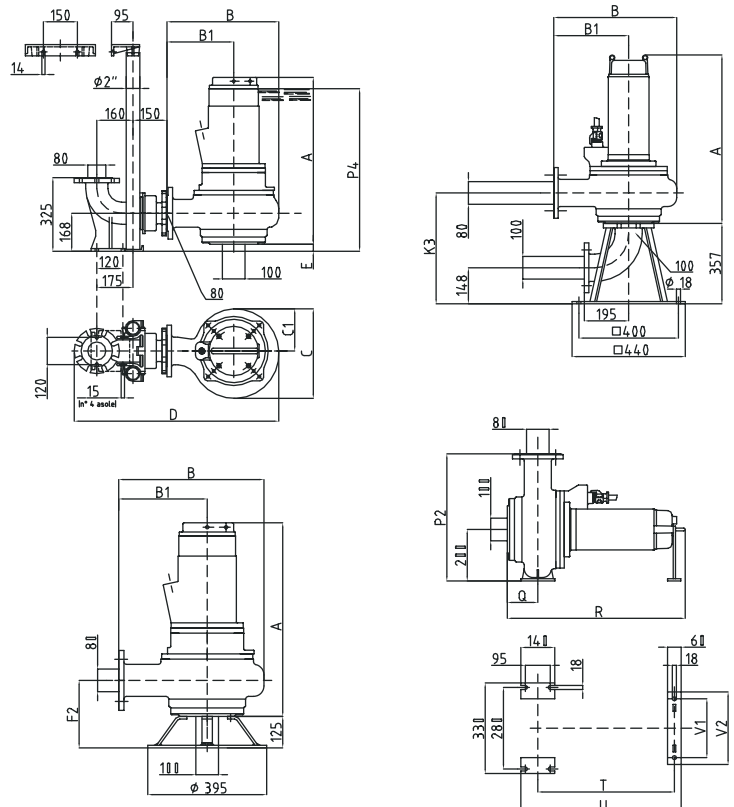

# FMc 80 - 2



CURVE DI PRESTAZIONE  
PERFORMANCE CURVES

ХАРАКТЕРИСТИЧЕСКИЕ КРИВЫЕ  
COURBE CARACTÉRISTIQUE

CURVA CARACTERÍSTICA  
CURVA CARACTERÍSTICA

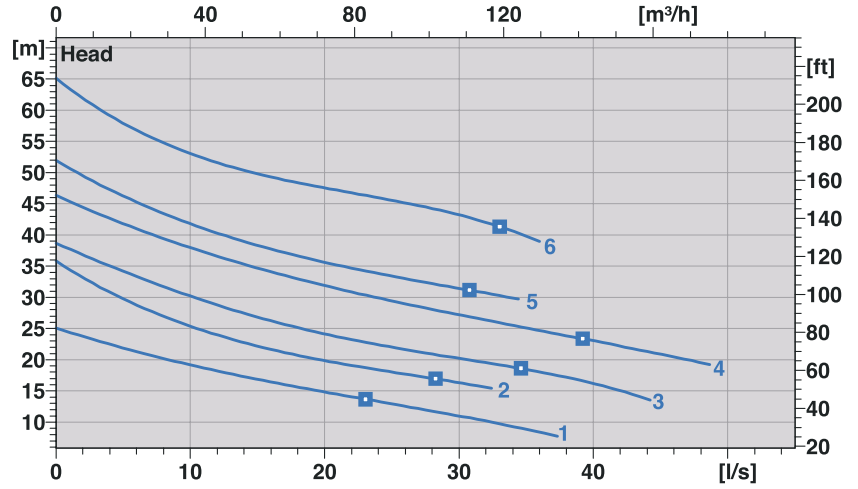

CARATTERISTICHE GENERALI - GENERAL FEATURES - ОСНОВНЫЕ ХАРАКТЕРИСТИКИ CARACTÉRISTIQUES GÉNÉRALES - CARACTERÍSTICAS GENERALES - CARACTERÍSTICA GERAIS									PRESTAZIONI - PERFORMANCES - РАБОЧИЕ ПАРАМЕТРЫ - PERFORMANCES - RENDIMENTO - EXECUÇÃO											
Nr	Modello - Type	P1 kW	P2 kW	Volt	Amp	Giri rpm	DN	Ø mm	l/sec m³/h	0	5	10	15	20	25	30	35	40	45	
1	FMc 80.9-2/150	10,5	9	3X400 Δ	18	2850	80	80		H m	25,8	22,6	20	17,5	15,4	13,5	11,5	9,4		
2	FMc 80.11-2/176	13	11	3X400 Δ	23	2850	80	80	37,5		32,3	27,8	24,3	21,3	19	16,7	14,3	12		
3	FMc 80.15-2/178	17	15	3X400 Δ	30	2850	80	80	40,2		35,5	31,4	28	25,2	23	21,2	19,5	17,2	14	
4	FMc 80.19-2/190	22	19	3X400 Δ	37	2850	80	80	47,9		43,5	39,7	36,3	33,3	30,7	28,4	26,3	24,2	22,1	
5	FMc 80.22-2/195	25	22	3X400 Δ	42	2850	80	80	53,6		48	43,5	40	37,2	34,8	32,7	30,7			
6	FMc 80.28-2/218	31	28	3X400 Δ	46	2850	80	80	65,2		58	53	49,8	47,5	45,6	43,3	39,8			

DIMENSIONI DI INSTALLAZIONE - INSTALLATION SIZES - УСТАНОВОЧНЫЕ РАЗМЕРЫ - DIMENSIONS D'INSTALLATION - DIMENSIONES DE INSTALACIÓN - DIMENSÕES DE INSTALAÇÃO																				
Nr	Modello - Type	A max	B	B1	C	C1	D	E	F2	K3	P2	P4	q	R max	T max	U max	V1	V2	V	KG
1	FMc 80.9-2/150	690	355	200	307	147	770	75	220	450	400	826	93	700	548	648	260	320	80N	105
2	FMc 80.11-2/176	690	355	200	307	147	770	75	220	450	400	826	93	700	548	648	260	320	80N	110
3	FMc 80.15-2/178	763	355	200	307	147	770	75	220	450	400	996	93	948	796	896	310	370	80N	175
4	FMc 80.19-2/190	763	355	200	307	147	770	75	220	450	400	996	93	948	796	896	310	370	80N	178
5	FMc 80.22-2/195	936	355	200	307	147	770	75	220	450	400	1085	93	948	796	896	310	370	80N	180
6	FMc 80.28-2/218	1051	459	280	363	165	869	49	243	476	480	1085	119	1063	886	986	310	370	80N	205

DIMENSIONI D'INGOMBRO  
DIMENSION DRAWINGS

ГАБАРИТНЫЕ ЧЕРТЕЖИ  
DIMENSIONS D'ENCOMBREMENT

DIMENSIONES TOTALES  
DIMENSÕES GLOBAIS

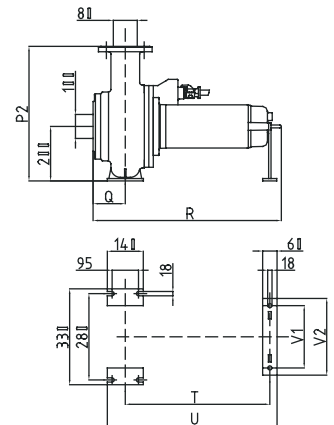
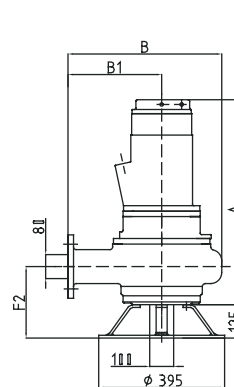
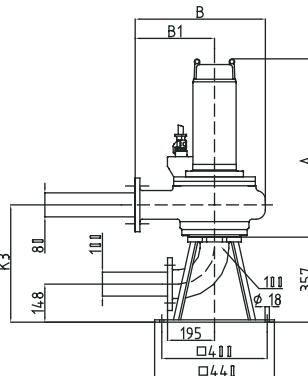
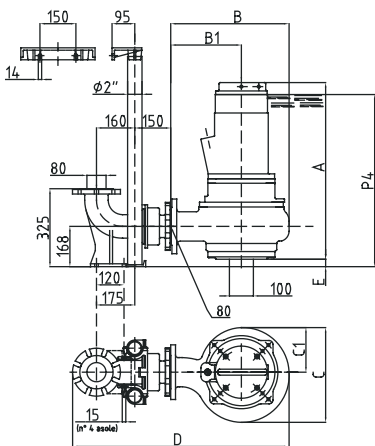



# FMc 100 - 4



CURVE DI PRESTAZIONE  
PERFORMANCE CURVES

ХАРАКТЕРИСТИЧЕСКИЕ КРИВЫЕ  
COURBE CARACTÉRISTIQUE

CURVA CARACTERÍSTICA  
CURVA CARACTERÍSTICA

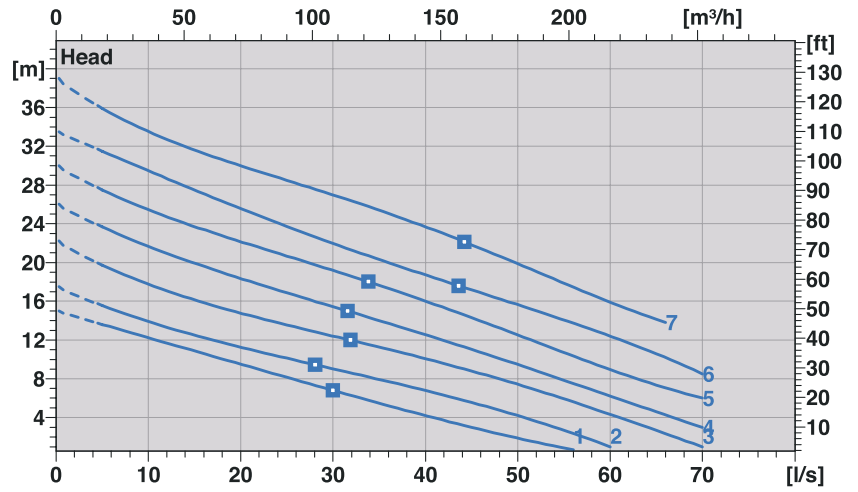

CARATTERISTICHE GENERALI - GENERAL FEATURES - ОСНОВНЫЕ ХАРАКТЕРИСТИКИ CARACTÉRISTIQUES GÉNÉRALES - CARACTERÍSTICAS GENERALES - CARACTERÍSTICA GERAIS										PRESTAZIONI - PERFORMANCES - РАБОЧИЕ ПАРАМЕТРЫ - PERFORMANCES - RENDIMENTO - EXECUÇÃO													
Nr	Modello - Type	P1 kW	P2 kW	Volt	Amp	Giri rpm	DN	Ø mm	l/sec m³/h	5	10	15	20	25	30	35	40	45	50	55	60	70	
1	FMc 100.3,5-4/200	4	3,5	3X400	7,5	1450	100	100	H m	13,3	12,5	11	9,3	8,3	7	5,5	4	3	2	1			
2	FMc 100.5-4/230	6	5	3X400 Δ	11	1450	100	100		15,6	14	12,7	11,2	10,2	9	8	7						
3	FMc 100.7,5-4/246	9	7,5	3X400 Δ	16	1450	100	100		20	17,8	16,1	14,8	13,5	12,5	11,4	10	8,8	7,3	6	4,4	1,2	
4	FMc 100.9-4/263	11	9	3X400 Δ	20	1450	100	100		23,5	21,5	20	18,5	17	15,6	14	12,6	11,1	9,5	8	6,5	3	
5	FMc 100.12-4/280	14	12	3X400 Δ	24	1450	100	100		27,5	25,5	23,8	22,3	20,9	19,4	17,7	16,1	14,4	12,4	10,6	9	6	
6	FMc 100.14-4/298	17	14	3X400 Δ	30	1450	100	100		31,3	29,4	27,5	25,6	23,9	22,2	20,5	18,8	17,2	15,8	14	12,3	9	
7	FMc 100.17,5-4/313	20	17,5	3X400 Δ	36	1450	100	100		35,8	33,4	31,5	30	28,8	27	25,5	23,7	21,9	20	18	16		

DIMENSIONI DI INSTALLAZIONE - INSTALLATION SIZES - УСТАНОВОЧНЫЕ РАЗМЕРЫ - DIMENSIONS D'INSTALLATION - DIMENSIONES DE INSTALACIÓN - DIMENSÕES DE INSTALAÇÃO																															
Nr	Modello - Type	A max	B	B1	C	C1	D	E	F2	G	K1	K2	K3	I	M	N	P1	P4	R max	S1	S2	S3	S4	T max	U max	V1	V2	DN1	DN3	V	KG
1	FMc 100.3,5-4/200	700	459	280	363	165	940	70	255	395	151	345	468	195	380	440	200	755	840	280	330	95	140	651	751	260	320	100	100	100N	104
2	FMc 100.5-4/230	700	459	280	363	165	940	70	255	395	151	345	468	195	380	440	200	755	840	280	330	95	140	651	751	260	320	100	100	100N	109
3	FMc 100.7,5-4/246	815	470	345	457	207	1056	65	260	450	199	470	605	271	440	500	250	800	1096	350	410	120	160	902	1012	310	370	150	150	100N	118
4	FMc 100.9-4/263	815	576	345	457	207	1056	65	260	450	199	470	605	271	440	500	250	800	1096	350	410	120	160	902	1012	310	370	150	150	100N	184
5	FMc 100.12-4/280	815	576	345	457	207	1056	65	260	450	199	470	605	271	440	500	250	800	1096	350	410	120	160	902	1012	310	370	150	150	100N	200
6	FMc 100.14-4/298	815	576	345	457	207	1056	65	260	450	199	470	605	271	440	500	250	800	1096	350	410	120	160	902	1012	310	370	150	150	100N	212
7	FMc 100.17,5-4/313	815	576	345	457	207	1056	65	260	450	199	470	605	271	440	500	250	800	1096	350	410	120	160	902	1012	310	370	150	150	100N	231

DIMENSIONI D'INGOMBRO  
DIMENSION DRAWINGS

ГАБАРИТНЫЕ ЧЕРТЕЖИ  
DIMENSIONS D'ENCOMBREMENT

DIMENSIONES TOTALES  
DIMENSÕES GLOBAIS

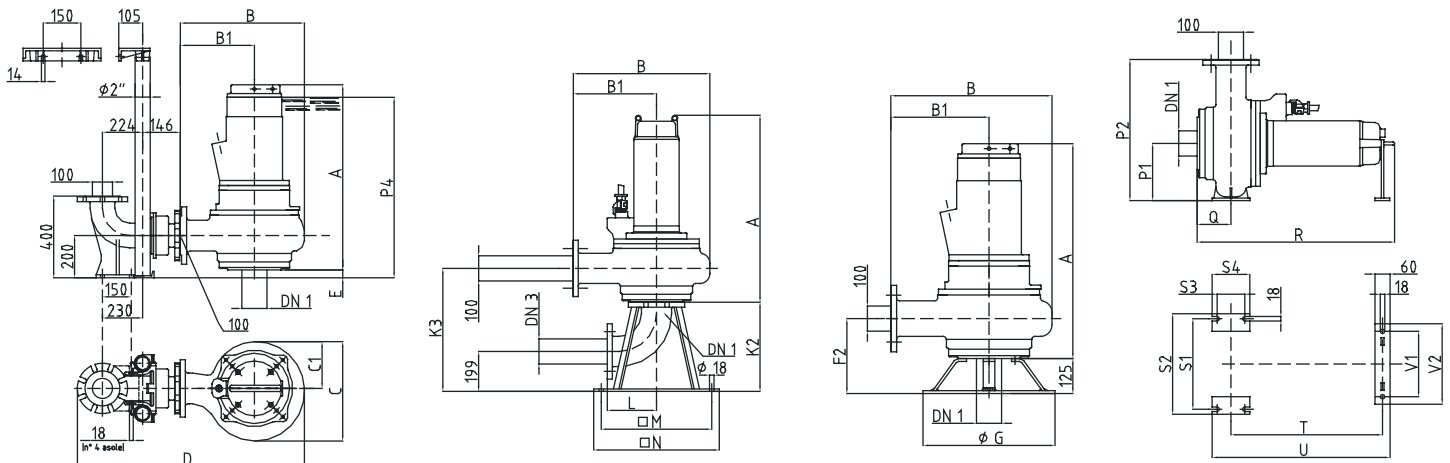

# FMc 150 - 6



CURVE DI PRESTAZIONE  
PERFORMANCE CURVES

ХАРАКТЕРИСТИЧЕСКИЕ КРИВЫЕ  
COURBE CARACTÉRISTIQUE

CURVA CARACTERÍSTICA  
CURVA CARACTERÍSTICA

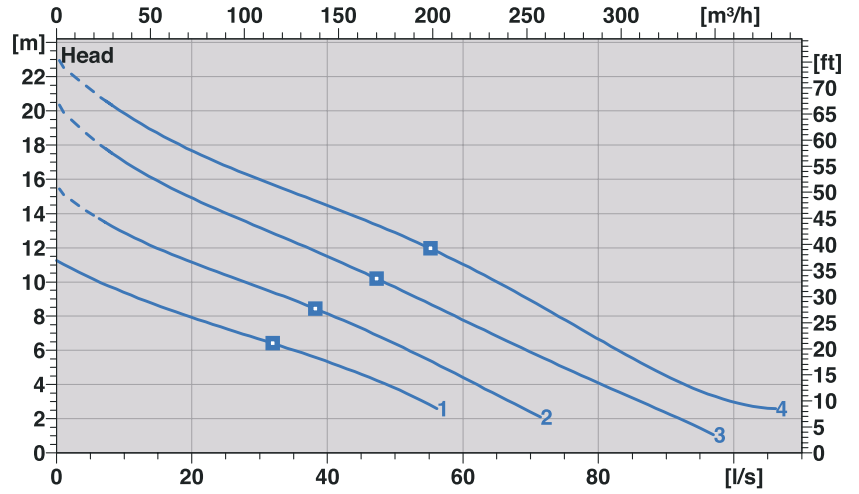

CARATTERISTICHE GENERALI - GENERAL FEATURES - ОСНОВНЫЕ ХАРАКТЕРИСТИКИ									PRESTAZIONI - PERFORMANCES - РАБОЧИЕ ПАРАМЕТРЫ - PERFORMANCES - RENDIMENTO - EXECUÇÃO												
Nr	Modello - Type	P1 kW	P2 kW	Volt	Amp	Giri rpm	DN	Ø mm	l/sec m³/h	10	20	30	40	50	60	70	80	90	100	120	
1	FMc 150.4-6/263	5,1	4	3X400	10,7	960	150	100	H	9	7,5	6,3	5,1	3,5							
2	FMc 150.5-6/313	6	5	3X400 Δ	12	960	150	100	m	12,3	10,5	9,2	7,7	5,9	4	2					
3	FMc 150.7,5-6/357	8,5	7,5	3X400 Δ	17	960	150	100		16,4	14,2	12,4	10,9	9,2	7,2	5,3	3,6	2,1			
4	FMc 150.10-6/372	11,6	10	3X400 Δ	22,5	960	150	100		19	16,8	15,1	13,6	12,3	10,4	8,3	6,1	4,2	2,2		

DIMENSIONI DI INSTALLAZIONE - INSTALLATION SIZES - УСТАНОВОЧНЫЕ РАЗМЕРЫ - DIMENSIONS D'INSTALLATION - DIMENSIONES DE INSTALACIÓN - DIMENSÕES DE INSTALAÇÃO																									
Nr	Modello - Type	A max	B	B1	C	C1	D	E	F2	P1	P2	P4	q	R max	S2	S3	S4	S5	T max	U max	V1	V2	V4	V	KG
1	FMc 150.4-6/263	800	608	370	468	209	1273	170	309	250	620	955	135	856	410	120	160	18	662	772	260	320	18	150N	158
2	FMc 150.5-6/313	800	608	370	468	209	1273	170	309	250	620	955	135	856	410	120	160	18	662	772	260	320	18	150N	160
3	FMc 150.7,5-6/357	870	690	420	548	241	1355	167	312	310	730	1022	138	1028	450	90	140	20	831	931	310	370	18	150N	265
4	FMc 150.10-6/372	1100	690	420	548	241	1355	167	312	310	730	1250	138	1029	450	90	140	20	831	931	310	370	18	150N	297

DIMENSIONI D'INGOMBRO  
DIMENSION DRAWINGS

ГАБАРИТНЫЕ ЧЕРТЕЖИ  
DIMENSIONS D'ENCOMBREMENT

DIMENSIONES TOTALES  
DIMENSÕES GLOBAIS

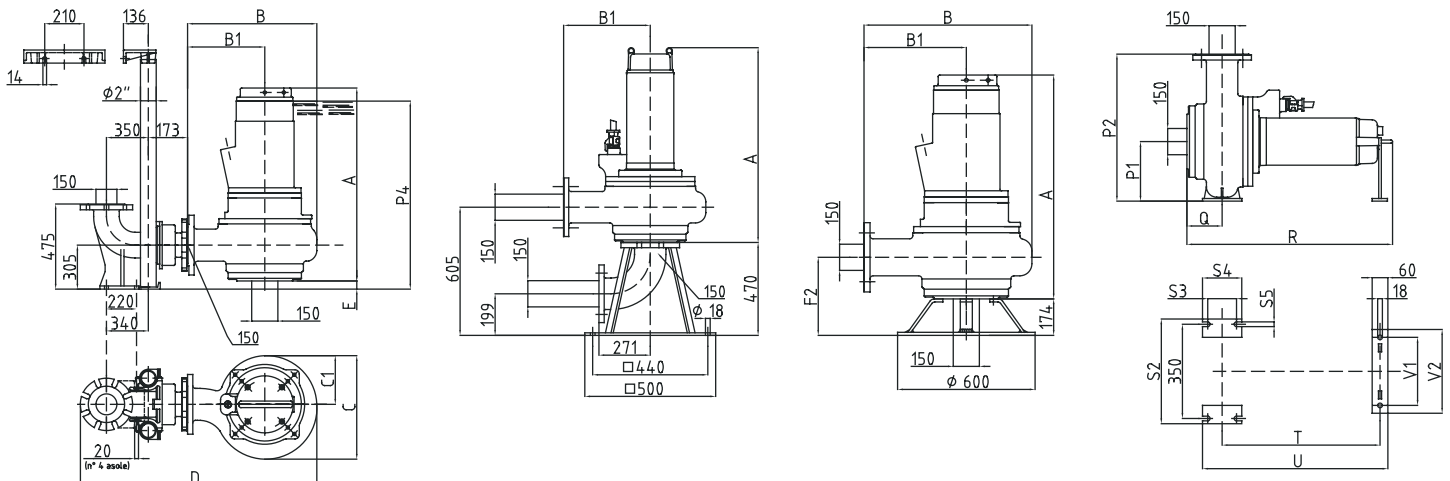

# FMc 150 - 4



CURVE DI PRESTAZIONE  
PERFORMANCE CURVES

ХАРАКТЕРИСТИЧЕСКИЕ КРИВЫЕ  
COURBE CARACTÉRISTIQUE

CURVA CARACTERÍSTICA  
CURVA CARACTERÍSTICA

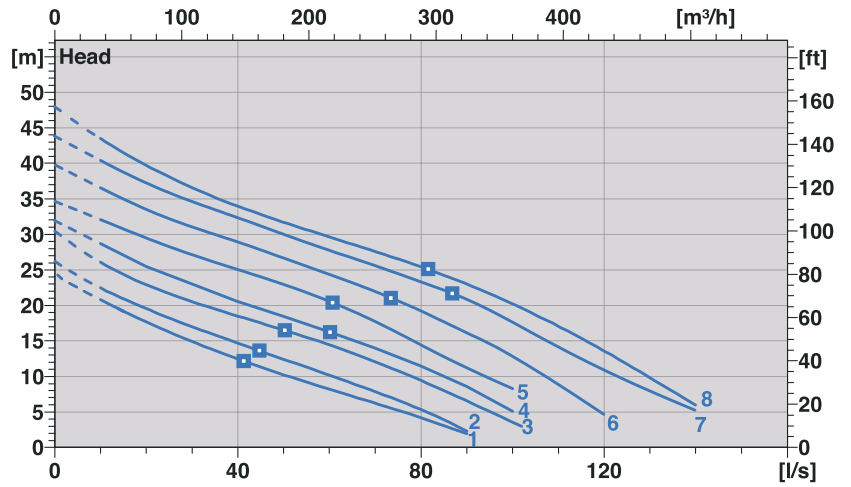

CARATTERISTICHE GENERALI - GENERAL FEATURES - ОСНОВНЫЕ ХАРАКТЕРИСТИКИ CARACTERÍSTICAS GENERALES - CARACTERÍSTICAS GENERALES - CARACTERÍSTICA GERAIS									PRESTAZIONI - PERFORMANCES - РАБОЧИЕ ПАРАМЕТРЫ - PERFORMANCES - RENDIMIENTO - EXECUÇÃO													
Nr	Modello - Type	P1 kW	P2 kW	Volt	Amp	Giri rpm	DN	Ø mm	l/sec m³/h	10	20	30	40	50	60	70	80	90	100	120	140	
1	FMc 150.9-4/263	11	9	3X400 Δ	20	1450	150	100	H	19,8	16,8	14,1	12	9,9	7,7	5,3	3,1					
2	FMc 150.12-4/280	14	12	3X400 Δ	24	1450	150	100	m	22,7	19,6	17	14,6	12,3	10,1	7,9	5,2	2,1				
3	FMc 150.14-4/298	17	14	3X400 Δ	30	1450	150	100		26	22,9	20,5	18,5	16,7	14,6	12,2	9,6	6,8	3,9			
4	FMc 150.17,5-4/313	20	17,5	3X400 Δ	36	1450	150	100		28,8	25,6	22,9	20,6	18,4	16,3	14	11,5	8,6	5,1			
5	FMc 150.22-4/345	25	22	3X400 Δ	45	1450	150	100		32	29,6	27,1	24,9	22,9	20,6	17,8	14,5	11	8,2			
6	FMc 150.26-4/357	29	26	3X400 Δ	48	1450	150	100		36,5	33,1	31,3	29,3	27	24,4	22,1	19,3	16	13,2	4,7		
7	FMc 150.34-4/372	39	34	3X400 Δ	68	1450	150	100		40,2	36,9	34,6	31,8	29,7	27,7	25,4	23,1	21	17,9	10,5	5,3	
8	FMc 150.30-4/367	33	30	3X400 Δ	60	1450	150	100		43	39,2	36,3	34	31,8	29,7	27,4	25,2	22,7	19,9	13,3	6,2	

DIMENSIONI DI INSTALLAZIONE - INSTALLATION SIZES - УСТАНОВОЧНЫЕ РАЗМЕРЫ - DIMENSIONS D'INSTALLATION - DIMENSIONES DE INSTALACIÓN - DIMENSÕES DE INSTALAÇÃO																											
Nr	Modello - Type	A max	B	B1	C	C1	D	E	F1	F2	G	P1	P2	P4	q	R max	S2	S3	S4	S5	T max	U max	V1	V2	V4	V	KG
1	FMc 150.9-4/263	820	608	370	468	209	1273	170	125	260	450	250	620	955	135	1096	410	120	160	18	902	1012	310	370	18	150N	190
2	FMc 150.12-4/280	820	608	370	468	209	1273	170	125	260	450	250	620	955	135	1096	410	120	160	18	902	1012	310	370	18	150N	192
3	FMc 150.14-4/298	820	608	370	468	209	1273	170	125	260	450	250	620	955	135	1096	410	120	160	18	902	1012	310	370	18	150N	218
4	FMc 150.17,5-4/313	820	608	370	468	209	1273	170	125	260	450	250	620	955	135	1096	410	120	160	18	902	1012	310	370	18	150N	222
5	FMc 150.22-4/345	1100	690	420	548	241	1355	167	174	312	600	310	730	1250	138	1341	450	90	140	20	1125	1225	360	420	20	150N	320
6	FMc 150.26-4/357	1100	690	420	548	241	1355	167	174	312	600	310	730	1250	138	1341	450	90	140	20	1125	1225	360	420	20	150N	410
7	FMc 150.30-4/367	1100	690	420	548	241	1355	167	174	312	600	310	730	1250	138	1341	450	90	140	20	1125	1225	360	420	20	150N	420
8	FMc 150.34-4/372	1100	690	420	548	241	1355	167	174	312	600	310	730	1250	138	1341	450	90	140	20	1125	1225	360	420	20	150N	430

DIMENSIONI D'INGOMBRO  
DIMENSION DRAWINGS

ГАБАРИТНЫЕ ЧЕРТЕЖИ  
DIMENSIONS D'ENCOUBREMENT

DIMENSIONES TOTALES  
DIMENSÕES GLOBAIS

