

ELECTRIC SUBMERSIBLE PUMPS SEMISOM/65

Electric pumps for professional applications to convey sewage water, entirely designed and manufactured in our Italian facility.



APPLICATION

To convey waste and sewage water from septic tanks.

To drain rain water.

To pump liquids containing solids, filaments and sewage keeping its biological process unchanged (4 poles version).

PERFORMANCE RANGE

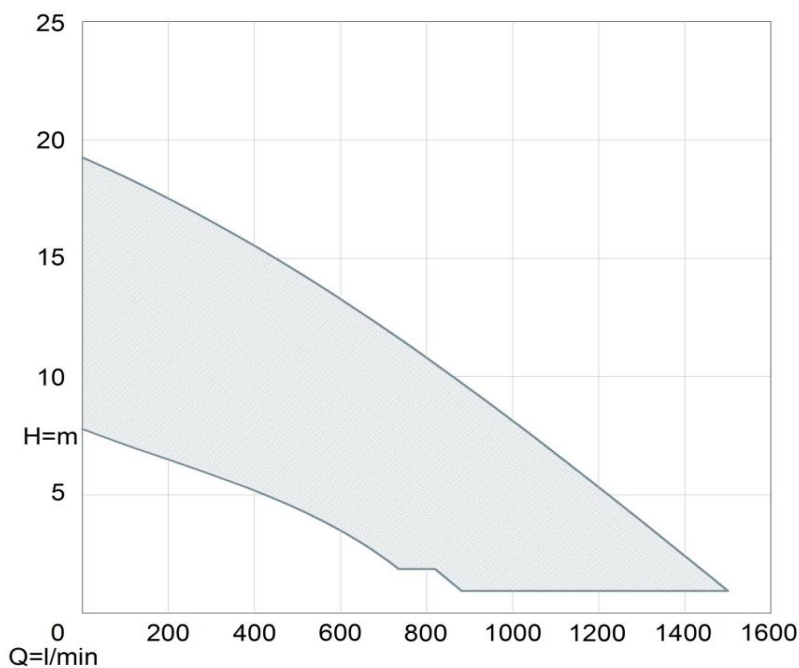

ELECTRIC SUBMERSIBLE PUMPS SEMISOM/65

TYPE OF THE ELECTRIC PUMP: SEMISOM 1100/65 T



TECHNICAL CHARACTERISTICS

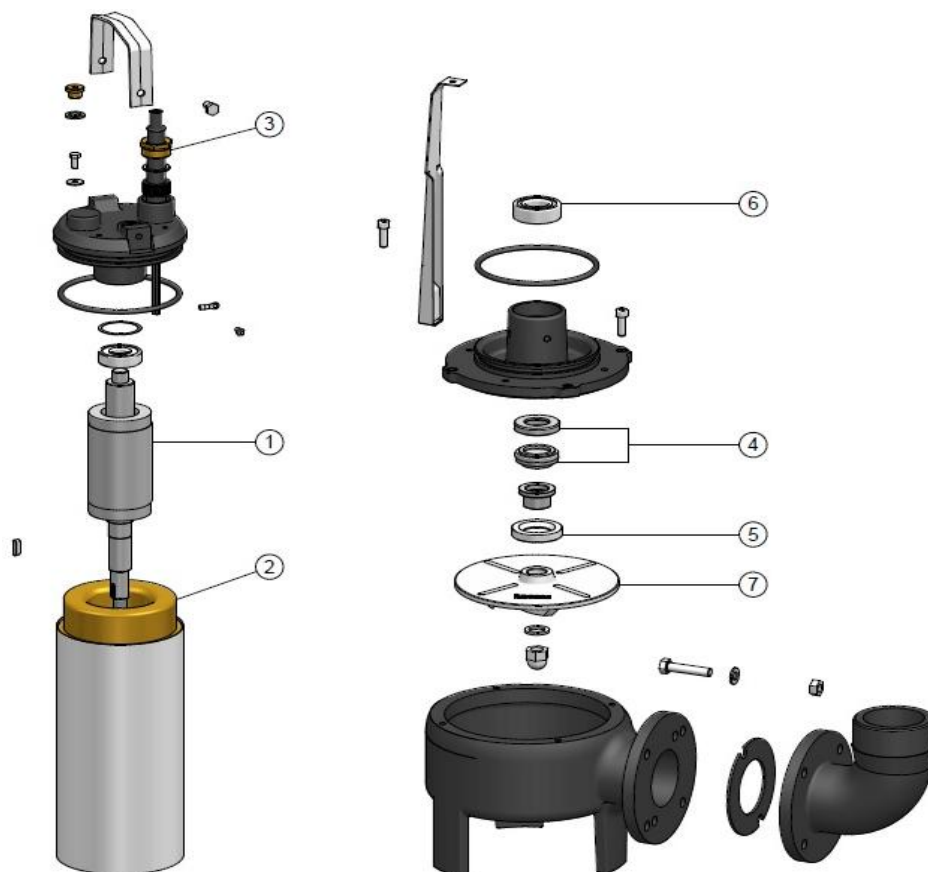

Shafts with grinded spots for ball bearings and mechanical seals (1).

Three-phase electric asynchronous rewindable motors with short-circuit rotor, coolant filled so to assure low working temperatures. Windings with phase insulators to protect the motor from power peaks, as a guarantee of a highly-trustworthy product (2). Resin-insulated cable kit to prevent penetration of water inside the motor (3).

Double sealing with oil chamber in-between. Silicon carbide and Alumina mechanical seal (4), external packing ring in rubber NBR (5).

Double-row lubricated and over-dimensioned ball bearings to grant a long life (6).

High-efficiency impellers (7).

MATERIALS

Tie rods, handle, motor casing, bolts and nuts	Stainless steel AISI 304
Shaft	Stainless Steel AISI 420B
Cover and pump body	Mechanical cast iron EN GJL-250
Impeller	Mechanical cast iron EN GJL-200
Mechanical seal	Silicon carbide and Alumina
Packing Ring	Rubber NBR
Elastomers	Rubber NBR
Cable	Neoprene H07RN-F



ELECTRIC SUBMERSIBLE PUMPS SEMISOM/65

TYPE OF THE ELECTRIC PUMP: SEMISOM 1100/65 T

HYDRAULIC CHARACTERISTICS

Type of impeller	Vortex
Inlet nominal diameter (mm)	65
Outlet nominal diameter (mm)	3"
Solid passage Ø (mm)	65

APPLICATION FEATURES

Protection degree	IP68
Duty	Continuous (S1)
Max immersion depth (m)	20
Max number of starts per hour	30
Max temperature of the liquid pumped (°C)	50
PH of the liquid pumped	6 - 10
Density of the liquid pumped (kg/dm³)	<1,1
Suitable for inverter drive	YES

PROTECTIONS

Thermal Protection	Responsibility of user
--------------------	------------------------

ELECTRICAL CHARACTERISTICS

Power (V)	400
No. of Phases	3
Frequency (Hz)	50
Insulation class	F
Nominal Speed (1/min)	2850
Nominal Power of the motor (kW)	2,2
Max absorbed power P1 (kW)	3,37
Start current (A)	8,7
Max. current (A)	6
No. of Poles	2

	Load		
	4/4	3/4	1/2
Power factor	0,81	0,75	0,63
Motor efficiency	74,8%	72,3%	66,3%

PERFORMANCE CURVES

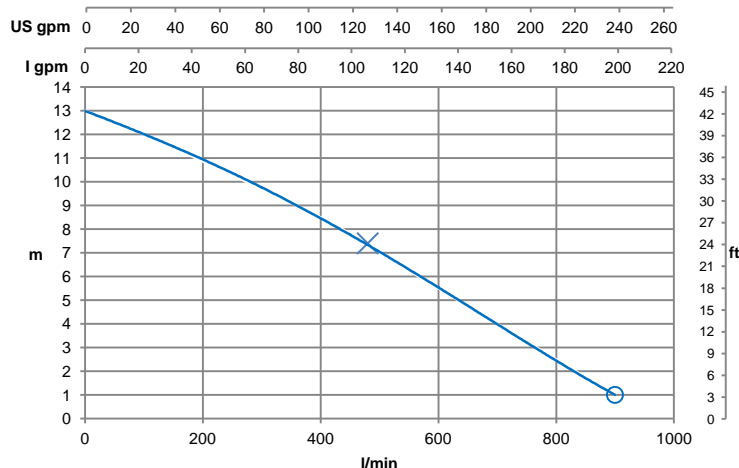

X = MAX. EFFICIENCY (Best Efficiency Point)

Total efficiency η_t (%)	18
Hydraulic efficiency η_i (%)	24
Absorbed power P1 (kW)	3,15
Hydraulic power P2 (kW)	2,4
Head (m)	7,4
Flow (l/min)	480

LIMITS

Flow max. (l/min)	900
Head max. (m)	13
○ = Minimum Head (m)	1

— η_i Hydraulic efficiency
— η_t Total efficiency

— P1 Absorbed power
— P2 Hydraulic power

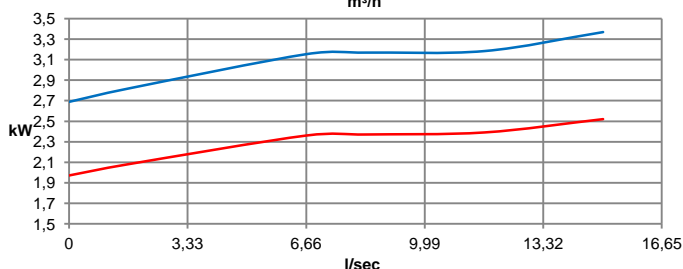
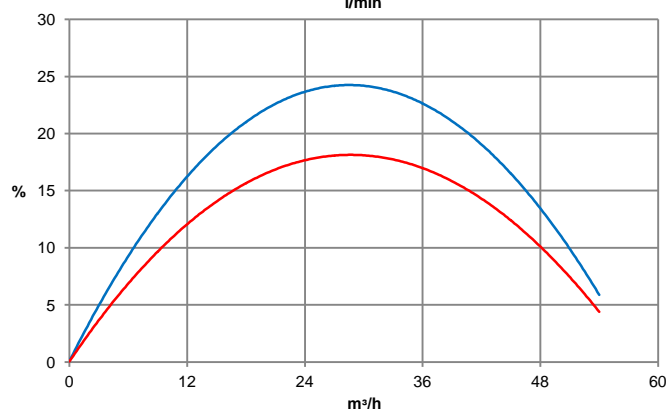

ELECTRIC SUBMERSIBLE PUMPS SEMISOM/65

TYPE OF THE ELECTRIC PUMP: SEMISOM 1100/65 T



DIMENSIONS AND WEIGHTS

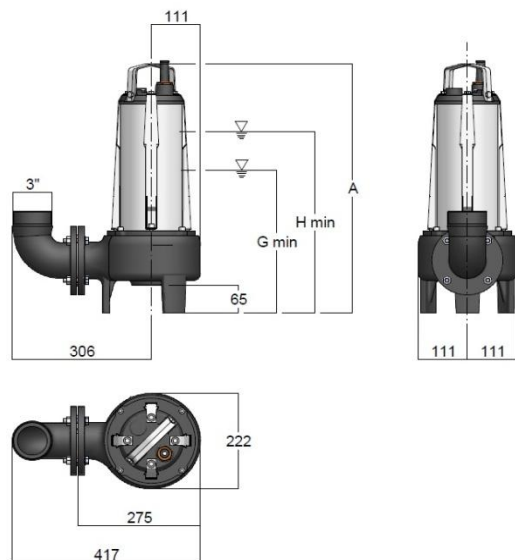

STANDARD VERSION

G = Minimum STOP level in case of automatic control (mm)	332,0
H = Minimum level of liquid in case of continuous duty (mm)	422,0
A = Total height (mm)	584,0
WEIGHT (kg)	40,0
Length of cable (m)	10,0

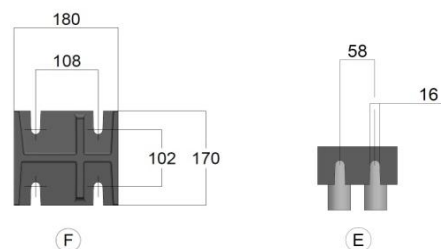
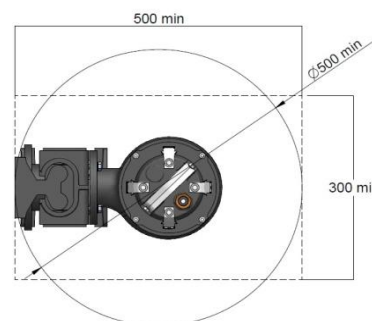
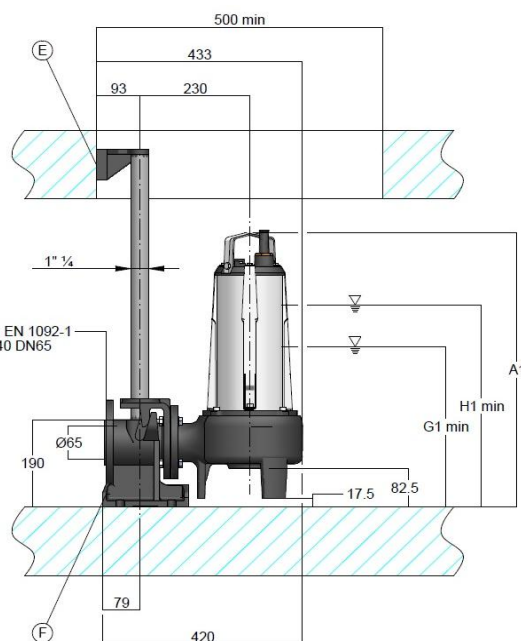

VERSION WITH GUIDE RAIL KIT

G1 = Minimum STOP level in case of automatic control (mm)	349,5
H1 = Minimum level of liquid in case of continuous duty (mm)	439,5
A1 = Total height (mm)	601,5

ELECTRIC SUBMERSIBLE PUMPS SEMISOM/65

TYPE OF THE ELECTRIC PUMP: SEMISOM 1100/65 T



ACCESSORIES

Code Description

05430110 FLANGED NON-RETURN BALL VALVE DN80 PN16



04105052 GUIDE RAIL KIT

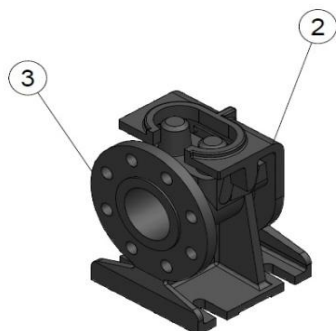
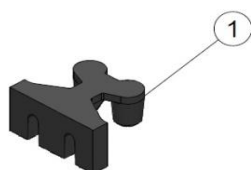

04105065 1.TOP BRACKET

04105060 2. CLAW

04105055 3. STOOL