

Saturn Package Pumping Station

The Saturn system is suitable for small housing estates, industrial and commercial developments, restaurants, small hotels, nursing homes, and caravan sites.

A dual station as standard, the Saturn system comes complete with internal pipework, non-return valves, high-level float switch and automatic control. The high-level alarm unit featuring light and audible alarm with a mute button comes as standard with this model.

The chamber is manufactured using strong virgin grade polyethylene, which makes this one of the most robust packaged pumping stations on the market. The strong access cover is constructed using galvanised mild steel and alternative options are available. 3(no.) lower level Ø160mm inlets will accommodate a standard drainage connection and the discharge connection is 63/80/100mm MDPE / HPPE.

Please Note: This product requires careful selection and our sales team will be pleased to advise on your requirements.



Features

Available in the following volumes:

2 metre deep = 3500 litres

3 metre deep = 5200 litres

4 metre deep = 7000 litres

4.5 meter deep = 7800 litres

- Pump chambers are well engineered and manufactured, and have passed rigorous and detailed testing, site inspections and factory production control assessment.
- Each pump chamber is made of strong, medium-density polyethylene
- Smooth internal walls aid the hygienic disposal of effluents, to avoid smells and septicity.
- Packages come complete with pipework pre-assembled in the chamber, ready for installation into the ground, after which the pumps and control equipment are added.
- All package pumping stations are supplied with controls for fully automatic operation, and a high-level alarm indicator.
- Units can be adapted to suit individual requirements at manufacturing stage.
- Packages are available on short lead-times to fit in with tight construction schedules.

T-T will help you to select the most compatible pump for your pumping station, depending on your requirements.

Application Range

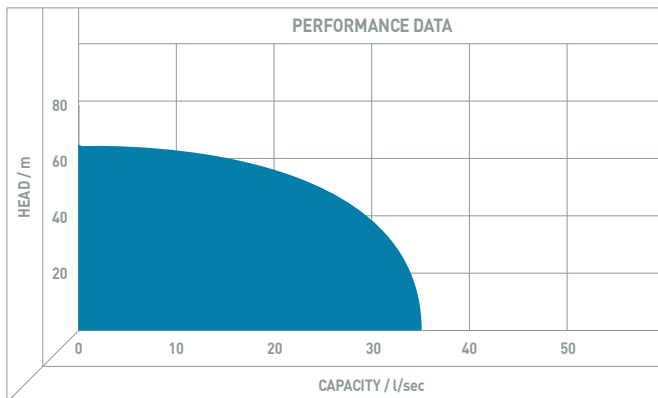

Due to the size range of the Saturn tank, it is able to accommodate a wide range of pumping equipment giving a wide application range to a maximum of 35 l/s at 65m head.

Dimensional Drawings

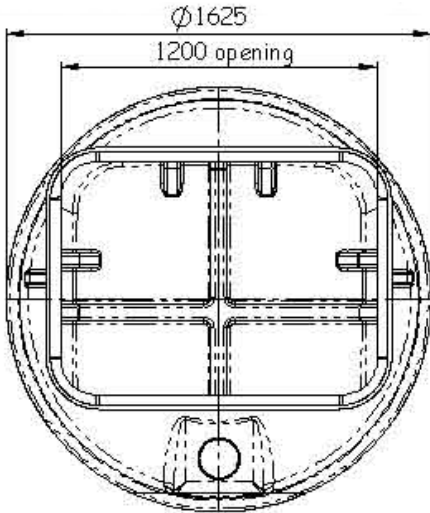

ARRANGEMENT OF TANK SECTIONS: -

A	TANK LENGTH	2000mm	A	TANK LENGTH	3000mm	A	TANK LENGTH	4000mm	A	TANK LENGTH	4500mm
B			B			B			B		
C			C			C			C		

WHERE 'B' = 500mm
'D' = 1000mm

