

# Verderflex

## Rollit 19 T Hygienic



VERDERFLEX®

### Description

The Verderflex Rollit 19 is the twin head hygienic version of the Rollit series of liquid-lubrication-free hose pumps, designed for applications in the biotechnology, chemical, food, pharma and many other industries.

### Features and benefits

- Self priming and dry running capability
- Excellent solids handling i.e. ideal for abrasive media
- Gentle pumping of sensitive media
- No seal or valves
- Pumping of viscous and aggressive media
- FDA CFR21 and EC/1935, optional ATEX

### Technical data

Max. flow rate	851 l/hr	Max. motor power	0.55 kW
Max. pump speed	165 RPM	Max. temperature of medium	80°C *
Max. discharge pressure	2 bar	Hose ID	19 mm
Max. suction lift	7 mWc	Weight (including motor)	55 kg

\* 80°C continuous use, 95°C intermittent

### Materials

Description	Materials	Paint detail
Pump housings	Aluminium Alloy	RAL 6018 (green) / RAL 7021 (black grey)
Rotors	Aluminium Alloy	
Roller	3 rollers PTFE with 25% Carbon per rotor	
Base Plate	Carbon Steel (option: Stainless Steel)	RAL 7021 (black grey)
Connector	Polypropylene hose tail Options: 316 Stainless Steel hose tail, 316 Stainless Steel BSP threaded, 316 Stainless Steel NPT threaded, 316 Stainless Steel BSPT BSP tapered thread, screw on 316 Stainless Steel ANSI 150lb flange, screw on DIN PN16 Stainless Steel flange and Camlock flexible connector hose adaptor	
Special order options	Tri Clamp, DIN 11851	
Hose options	Verderprene according to FDA CFR21 & EC/1935	

### Options and accessories

- Special drive design depending on customers demands
- Mechanical or electronic adjustment of speed and flow
- Quick-coupling systems, flanges, hygienic fittings
- Pulsation dampers
- Hose monitor
- Mobile mounting available
- Special paint finishes
- Pump control systems
- Dosing systems



# Verderflex

## Rollit 19 T Hygienic



VERDERFLEX®

### Performance curve

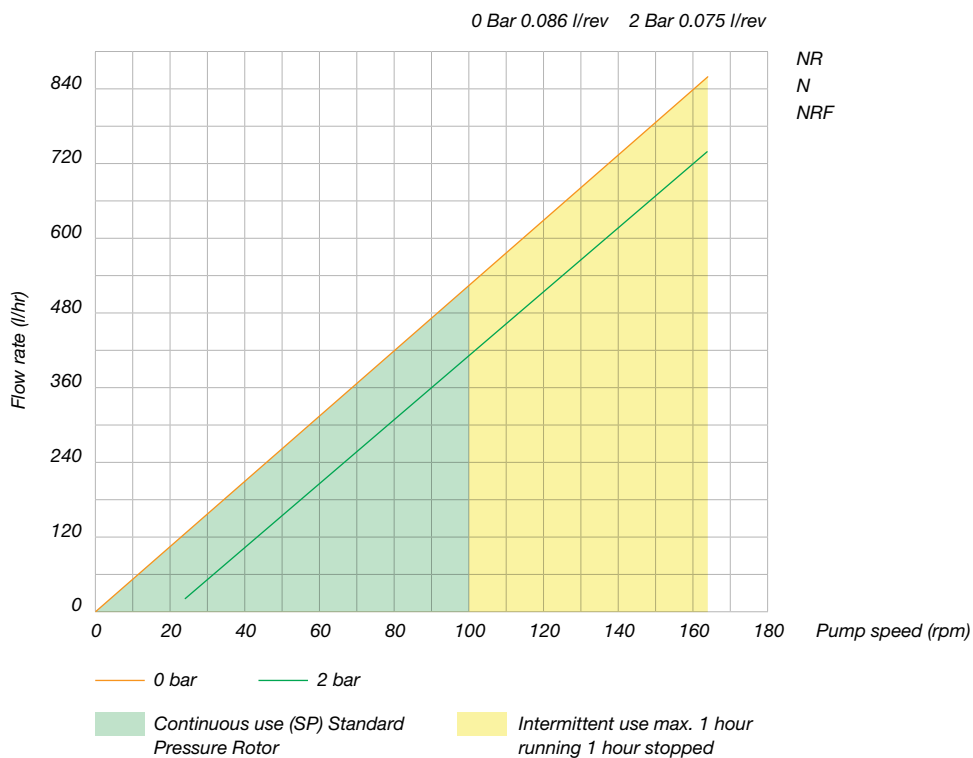

Flows are typical and were measured with water at 20°C with no suction lift or discharge pressure. Actual flows will vary according to suction conditions, discharge pressure and normal component production tolerances.

### Dimensions

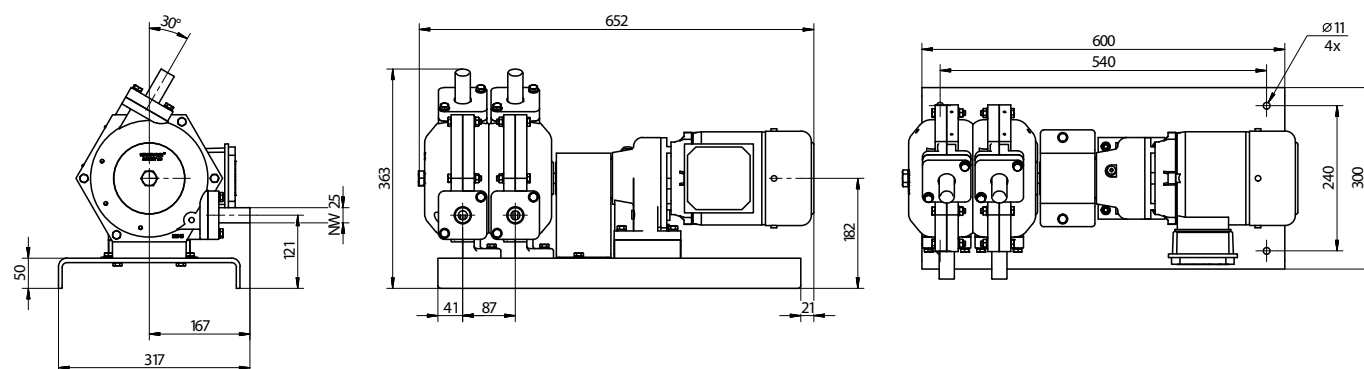

All dimensions are in mm.  
All dimensions and weights are for guidance only.

Find your local supplier at [www.verderflex.com](http://www.verderflex.com)

For construction, installation and floor mounting drawings please contact your local authorised Verderflex® distributor.

**VERDER**  
passion for pumps

